

# Cheongsam Dress 02/2012

By: burda style magazine

<http://www.burdastyle.com/projects/cheongsam-dress-022012>

---



Chinese cheongsam dress sewing pattern. This tight-fitting version of the traditional Chinese cheongsam dress was made popular in 1920's Shanghai and is a stylish great fitting piece of clothing. Also known as qipao or mandarin gown.

## Materials

Silk crepe, fabric width: 135 cm (53 in) length of black : 1.20 1.25 1.25 1.30 1.30 m (13/8 11/2 11/2 11/2 11/2 yds) length of yellow: and 1.20 1.20 1.25 1.25 1.25 m (1 3/8 1 3/8 1 1/2 1 1/2 1 1/2 yds). Vilene/Pellon G 785. 1 invisible zip, 40 cm (16 ins) long, and a special presser foot. 5 small sew-on snap fasteners.

---

## Step 1 — Preparations



Paper cut for ANSI A (German DIN A4) prints:

This pattern is printed on 8.5 × 11 sheets of plain paper. Do not scale or center pages before printing. Wait until all sheets are printed out before beginning to tape them together. **Do not cut out pattern pieces yet**— Arrange the sheets on a large, hard, flat surface so that they fit together, matching up like numbers and letters (i.e. 6A to 6A). To tape pattern together, fold under the margin of one piece (6A) and tape right against the line of it's matching number/letter (6A).

Trace the pattern pieces from the pattern sheet. Tape piece 4 and 4a together along the joining lines. Trace the inside band pieces from piece 4 (upper piece above marked upper line, lower piece below marked lower line). Trace piece 3 twice from the pattern sheet, noting the different lines for the right and left pieces. The placement line on piece 2 is marked on the pattern for size 36. For the other sizes, remark the line at the same width.

**burda style magazine pattern do not have seam allowance included.**

Seam and hem allowances to be added: Centre back seam, side seams and shoulder seams 1.5 cm (5/8 in). All remaining seams 1 cm (3/8 in).

---

## Step 2 — Cutting out

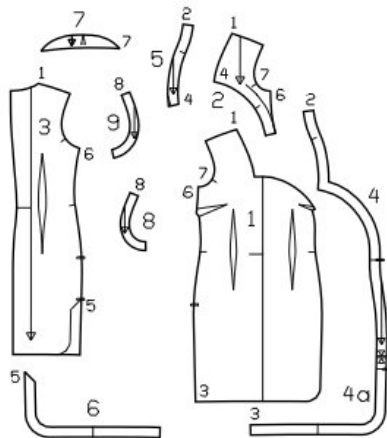

Black silk crepe, 135 cm wide

Yellow silk crepe, 135 cm wide

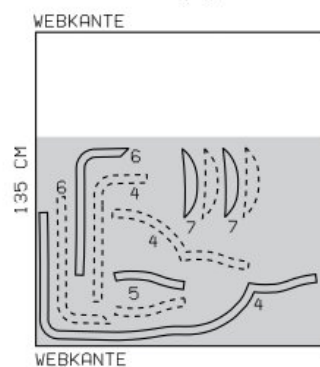
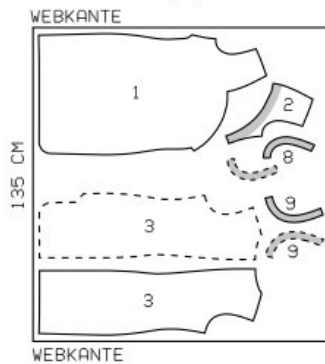

Stoffbruch = fold  
Webkante = selvage

Black fabric:

- 1 front , cut 1x
- 2 upper left front, cut 1x
- 3 right back, cut 1x
- left back, cut 1x
- 8 front armhole facing, cut 2x
- 9 back armhole facing, cut 2x

Yellow fabric:

- 4 front band with right neck band, cut 1x
- upper inside band piece, cut 1x
- lower inside band piece, cut 1x
- 5 left neck band, cut 2x
- 6 back hem band, cut 2x
- 7 armhole band, cut 4x

Important: Cut the inside band pieces as mirror images of the outside band pieces.

Interfacing: Iron a shaped strip of interfacing approx. 3 cm (1 1/4 ins) wide, on the lower edge of the upper left front. For best results, iron the interfacing onto wrong side of the fabric before cutting out the bands.

### Step 3 — Sewing

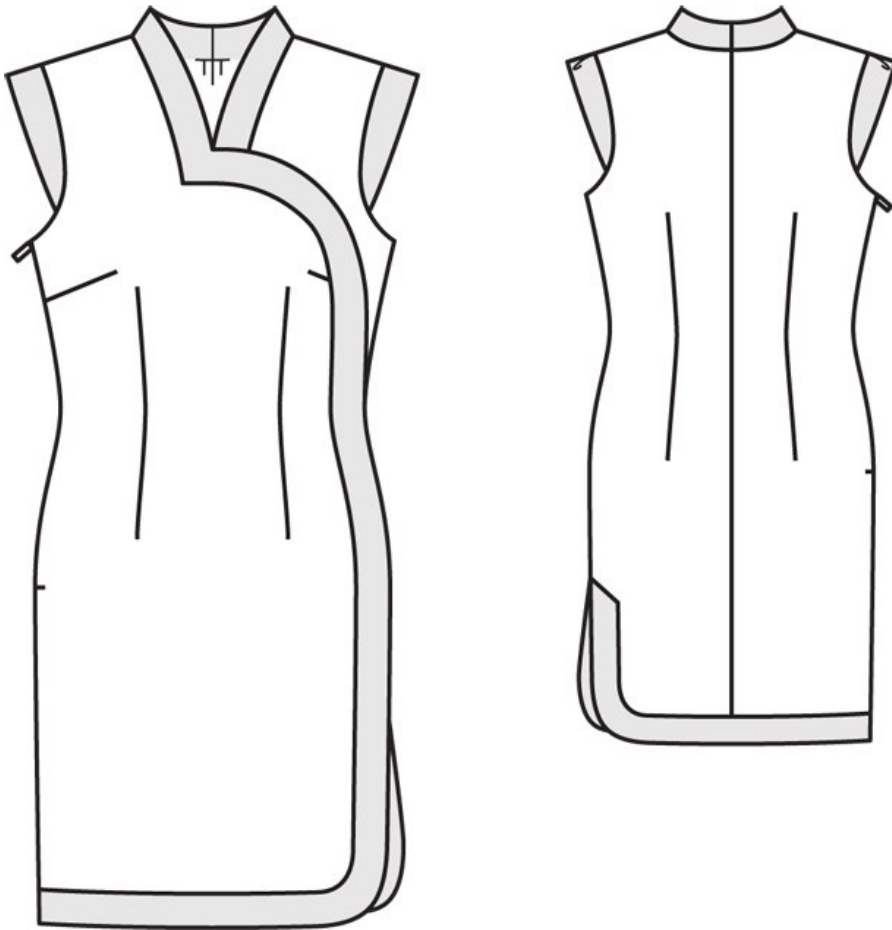

Lay the left back piece right sides together with the right back piece. Line up, pin and sew the centre seam on the back. Press the seam allowances open.

Stitch the darts. Press vertical darts toward centre. Press bust darts down.

Lay the front piece (number 1) and the upper left front piece (number 2) right sides together with the back piece. Line up, pin and stitch the shoulder seams (seam number 1).

Stitch the centre back seam of the neck band. Stitch the front band to the front, from seam number 3, and continue stitching to stitch the neck band to the neck edge, from seam number 4, clipping the seam allowance of front into corner and clipping the seam allowance of the band several times along curves. Stitch the back hem band to the back, on the left side clipping the seam allowance of the back into the corner. Clip the seam allowance of the band several times along the curve. Press the seam allowances onto the bands.

Lay the inside band pieces right sides together with the attached bands and pin the band edges together. Beginning at right side edge, stitch front band in place along lower edge and side edge, down to bottom slit mark. Beginning at top slit mark, stitch to side band edge, then along neck edge to bottom end of left neck band. At the slit marks, turn the extending narrow ends of the inside bands back and pin in place. On the back

hem band, stitch along the lower edge and left side edge, to the slit mark. Turn the extending end back and pin in place.

Sew invisible zipper to the right slit edges. For the right side seam, turn the inside band pieces down and stitch seam from lower edge to zip. Press the seam allowances open.

Lay the upper left front on the back, right sides facing, and stitch to the side seam edge, ending stitching at marked lower edge. Fold the seam allowance up and pin. Lay the front with the band right sides together with the back. Pin the side edge of the front band to the side seam edge, between the slit marks. Stitch the side seam, down to the bottom slit mark.

Remove the pins. Turn the inside bands to the inside. Press the left side seam and the edges of the band. Turn in the inside edge of the bands and baste over the joining seams. Work from the right side of the dress to stitch along seam, catching inside edges.

Lay each interfaced armhole band on armhole band with no interfacing, right sides together. Stitch the armhole bands together on the straight edge. Turn the bands right side out and press. Baste the open edges together. Work from the inside to stitch the pleat, up to the arrow marking. Lay the pleat in direction of arrow and press the pleat seam. Baste the bands to the edges of the armholes, above the markings.

Stitch the shoulder seams of the armhole facings. Stitch the side seam of the left facing (as mirror image of dress). Pin the right armhole facing right sides together with the right armhole edge. At the zip slit, turn the facing back, approx. 5 mm (3/16 in) before edge of opening, and pin to the armhole. Turn the allowances on the slit edges to outside and pin to the armhole, over the facing. Stitch along line of armhole. Trim the seam allowances. Turn the allowances on the slit edges to the inside. Turn the facing over the seam allowances, into the armhole, and stitch to the seam allowances, close to the seam, as far as possible. Turn the facing to the inside and sew to the zip tapes and the shoulder seam. Stitch the left armhole facing to the left armhole, right sides together. Trim the seam allowances. Turn the facing over the seam allowances, into the armhole, and stitch to the seam allowances, close to the seam. Turn the facing to the inside. Sew the inside edge of the facing to the seams.

Pin the front band to the upper left front, to meet marked placement line. Stitch the front to the lower edge of the upper left front, along line of band joining seam, approx. 10 cm (4 ins) long, stitching from the bottom end to the seam mark. Fasten the front band to the upper left front with 5 small snaps, spaced evenly apart.

---

**BurdaStyle**

Cheongsam Dress 02/2012