

Lydia

By: burdastyle

<http://www.burdastyle.com/projects/lydia>



A basic, long-sleeve shirt that is destined to be one of your wardrobe staples. Make it in a single weekend, and make multiples to pair with your favorite jeans and khakis. We have also made a cool variation, which includes a hood. Check it out [here](#).

Materials

Jersey, Rib Knit

Step 1





**burda Download-Pattern
Shirt 3197 - Instructions**

very easy

close fitting

burda sizes	Eur.	45 ins / 114 cm • 55 ins / 140 cm • 59 ins / 150 cm							
		32	34	36	38	40	42	44	
	yds	1 1/2	1 1/2	1 1/2	1 1/2	1 1/2	1 1/2	1 1/2	1 1/2
	m	1.35	1.35	1.35	1.40	1.40	1.40	1.40	1.40

IMPORTANT! extra fabric required to horizontally striped fabrics. * without nap

-  right side
-  wrong side
-  interfacing
-  lining
-  batting

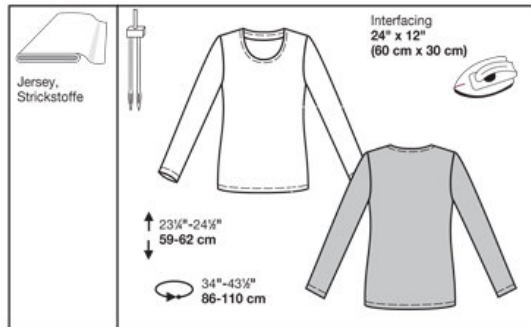

Patternpieces:

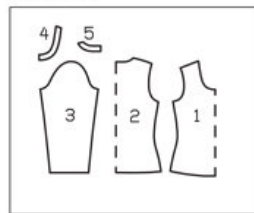

- 1 Front piece 1x
- 2 Back piece 1x
- 3 Sleeve 2x
- 4 Front trimming 1x
- 5 Back trimming 1x

Fabrics: Jersey, knit fabrics

Step 2



The patterns can be printed out at the copy shop. If you decide to print them at home, follow the instructions: Paper cut for ANSI A (German DIN A4) prints:

The patterns are printed out on 20 sheets with a thin frame. Wait, until all sheets are printed out. Arrange the sheets so that they fit together (see extra page with the overview of the prints). Cut off the single sheets on the upper and right edge along the thin frame lines. Begin with the left lower sheet and then glue the parts in

the frame lines together precisely.

Step 3

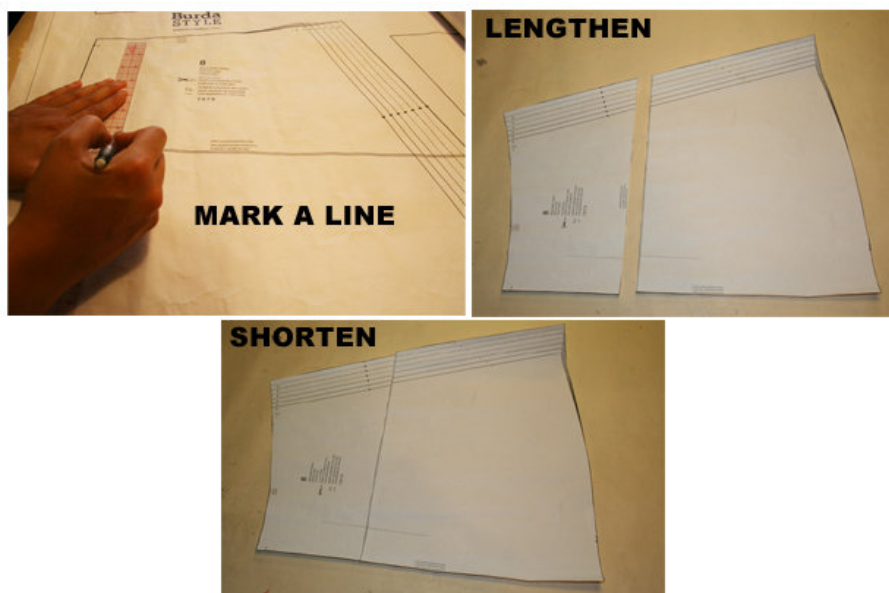

ADJUST PATTERN SIZES

Select your size according to the Burda-dimension table: Dresses, blouses, jackets and coats according to the bust

size, trousers and skirts according to the hip width. Change the patterns according to size (inches or cm) if necessary, to fit your measurements if they deviate from the Burda-dimension table. (a)

Cut out the pattern according to your size.

Refer to our “ Adjust patterns for mixed sizes” technique

LENGTHENING OR SHORTENING THE PATTERN PIECES

Our pattern is calculated for a height of 5’ 6” (168 cm). If you are taller or shorter, you can adjust the pattern pieces along the lines marked “lengthen or shorten here”. This way the proper fit is maintained.

Always adjust all pattern pieces along the same line to the same degree (b).

How to lengthen and shorten pattern pieces:

Cut the pattern pieces along the marked lines

To lengthen, slide the two halves of the pattern piece as far apart as necessary.

To shorten, overlap the two halves of the pattern piece as far as necessary. Blend the side edges ©.

Step 4

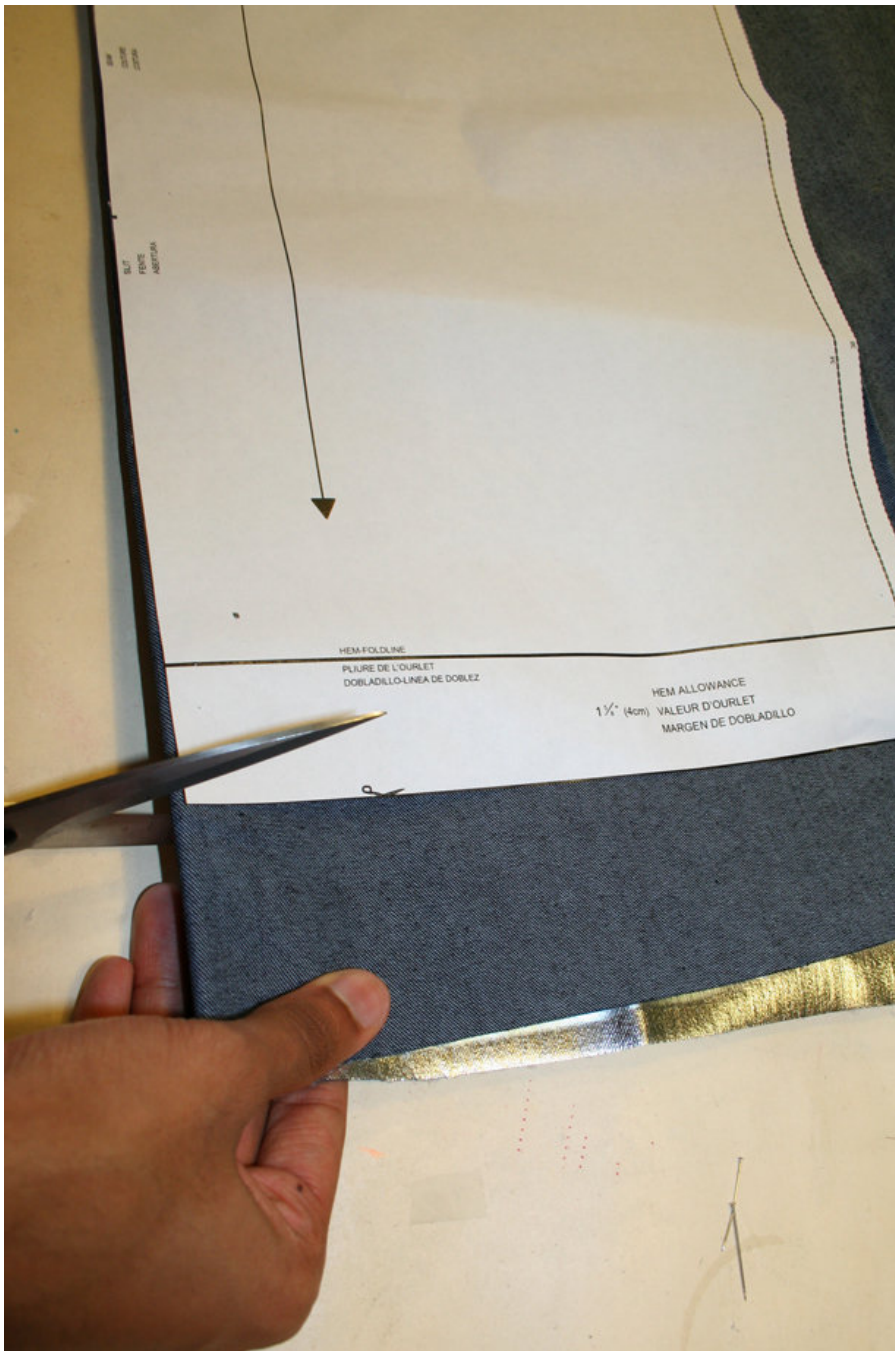

CUTTING OUT

FOLD () means: here is the center of a pattern piece but never a cut edge or a seam. The piece should be cut double, with the fold line forming the centre line. Pattern pieces that are outlined with a broken line in the cutting diagrams are to be placed face down on the fabric.

The cutting diagrams on the pattern sheet show how the pattern pieces should be placed on the fabric. For a single layer of fabric, the pattern pieces are pinned to the right side of the fabric. For double layers of fabric, the right sides are facing and the pattern pieces are pinned to the left side. The pattern pieces that are shown in the

cutting diagram, extending over the fold of the fabric, should be cut last from a single layer of fabric.
Important: Trim the skirt pattern pieces from the single layer of fabric, the pattern pieces are pinned to the right side of the fabric, the labeled pattern side on top = see cutting diagram

Step 5

INTERFACING

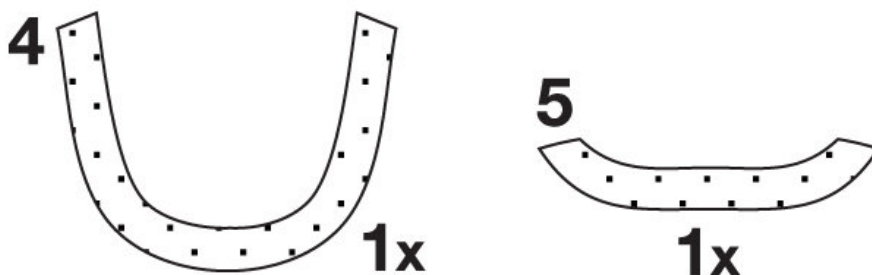

SEAM AND HEMLINE ALLOWANCES are included on an average:
5/8" (1.5 cm) for all edges and seams. Use BURDA carbon paper to transfer all pattern lines and markings to the left side of the fabric pieces. You will find instructions in the packet.

INTERFACING

Cut interfacing according to the drawing and press onto the left fabric side

SEWING

When sewing the right fabric sides are facing.

Transfer all lines on the pattern using a basting stitch to the right fabric side.

Tips for working with stretchable fabrics

The optimal result from working with stretchy fabrics will be achieved by using an overlock-machine. Seams will become very elastic and more durable, and will not break when wearing the finished clothes. If you are not going to use an over-lock machine, stitch the seams using an elastic special stitch or a narrowly adjusted zigzag stitch. Please take care that the thread tension is not set too high. For delicate mesh fabrics it is necessary to use a Jersey needle for stitching with your sewing machine.

Step 6

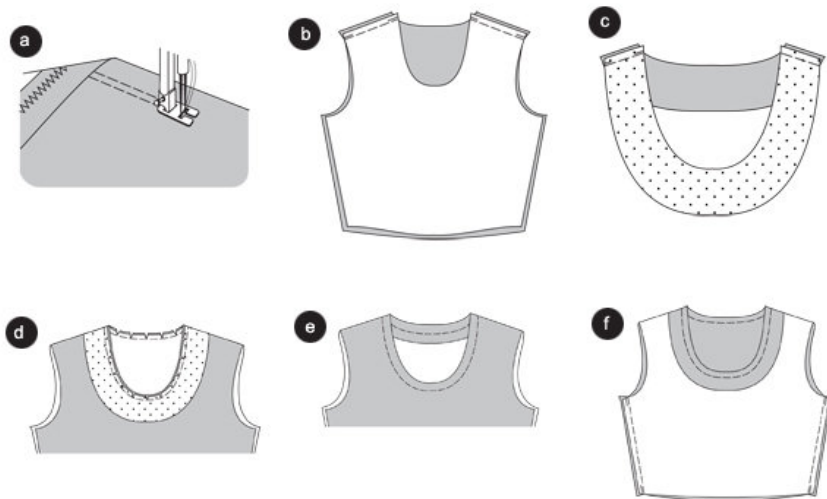

Fold edges, for stitching of the edges (e.g. at the hem) use a twin needle. Stitch along the right fabric side using two upper threads and one under thread, using the straight stitch setting. In this case the under thread will appear as zigzag stitch. The result will be that the fabric will not stretch when sewing and the seam will be elastic. (a)

SHIRT

Shoulder seams

Position front piece on top of the back piece, right sides facing (seam 1). Trim allowances, neaten altogether and fold and press inwards towards the back piece. (b)

Neckline / Facing

Position the front facing onto the back facing right side to right, stitch shoulder seams (seam 2). Neaten edge. ©

Pin facings onto the neckline right side to right, shoulder seams meet. Baste trimming and stitch. Trim allowances and cut in to make the neckline more flexible. (d)

Fold inside and baste facing, press. Stitch neckline 1/2" (1.5 cm) wide from the edge. (e)

Side seams

Position front piece onto the back piece, right sides facing, baste side seams (seam 3) and stitch. Trim allowances, neaten altogether and fold and press inwards towards the back piece. (f)

Step 7

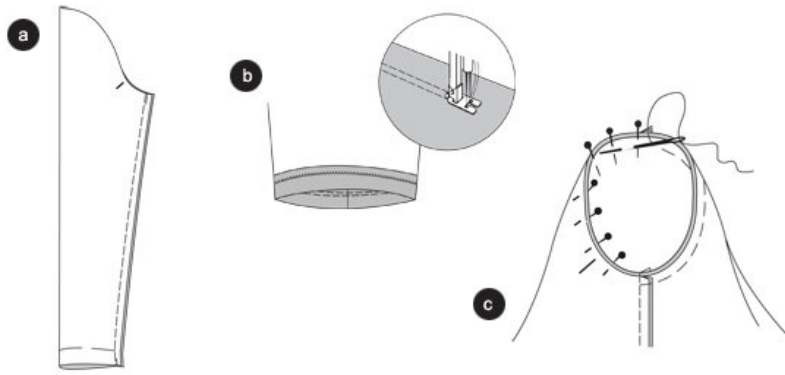

Sleeves

Fold sleeve lengthwise, right sides inwards. Baste sleeve seams (seam 4) and stitch. Trim allowances, neaten altogether, fold and press inwards towards the back piece.(a)

Sleeve seam

Fold and baste sleeve hem, press. Stitch bottom sleeve edge using a twin needle approximately 1â€ (2.5 cm) wide, baste the seam simultaneously. (b)

Apply sleeves

Pin the sleeves onto the armhole right sides facing. 3 points are essential for the fit of the sweater when you apply the sleeves: = the notch 5 of the top sleeve and the front piece have to meet. Sleeve seams and side seams have to meet. The notch of the sleeve rounding has to meet the shoulder seam. Baste and stitch the sleeve from the view of the sleeve side. Trim allowances, neaten altogether and press inwards into the sleeve. Stitch hem. ©

BurdaStyle

Lydia