

# Sibylle

By: burdastyle

<http://www.burdastyle.com/projects/sibylle>

---



Raise the curtain for our short little summer number. Whatever event it may be that you are trying to find the perfect dress for, this one will do! Unless too cute is off limits. Find either a great chiffon and satin match or something contrasting to bring out the mix of different fabrics. With its chiffon top this dress may not be



19 Loop (for shoulder straps) 2x

Fabrics: I: Satin, II: Chiffon, Ruffle: Tulle

---

## Step 2



The patterns can be printed out at the copy shop. If you decide to print them at home, follow the instructions: Paper cut for ANSI A (German DIN A4) prints: The patterns are printed out on 45 sheets with a thin frame. Wait until all sheets are printed out. Arrange the sheets so that they fit together (see additional page with the overview of the prints). Fold the single sheets on the upper and right edge along the thin frame lines. Begin with the left lower sheet and then tape the frame lines together precisely.

---

## Step 3

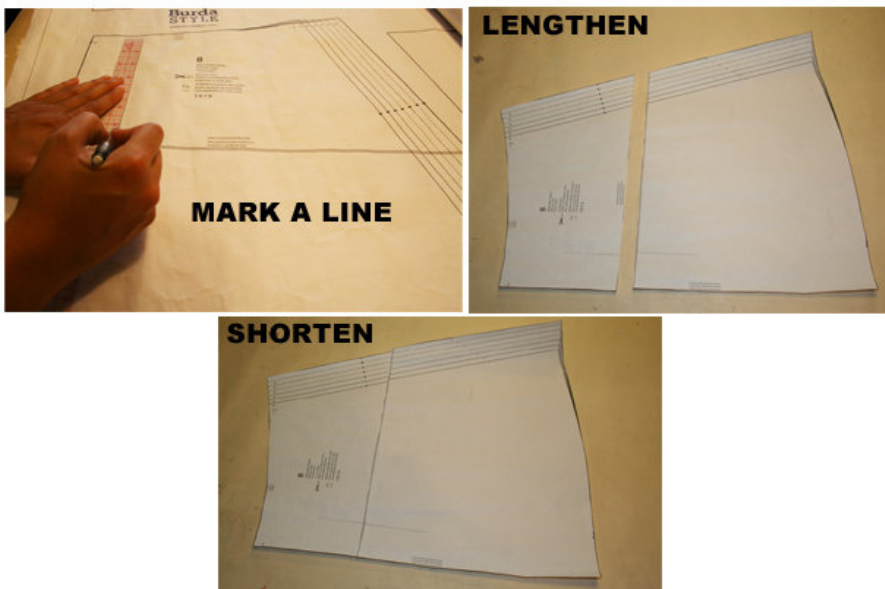

## ADJUST PATTERN SIZES

Select your size according to the Burda-dimension table: dresses, blouses, jackets and coats according to the bust size, trousers and skirts according to the hip width. If necessary, change the pattern to fit your measurements if they deviate from the Burda-size chart. Cut out the pattern according to your size. Refer to our “ Adjust patterns for mixed sizes” technique

## LENGTHENING OR SHORTENING THE PATTERN PIECES

Our pattern is calculated for a height of 5’ 6” (168 cm). If you are taller or shorter, you can adjust the pattern pieces along the lines marked “lengthen or shorten here”. In this way the proper fit is maintained. Always adjust all pattern pieces along the same line to the same degree.

How to lengthen and shorten pattern pieces:

Cut the pattern pieces along the marked lines.

To lengthen, slide the two halves of the pattern piece as far apart as necessary.

To shorten, overlap the two halves of the pattern piece as far as necessary. Blend the side edges.

---

## Step 4



## CUTTING OUT

FOLD ( ) means: here is the center of a pattern piece but never a cut edge or a seam. The piece should be cut double, with the fold line forming the center line. Pattern pieces that are outlined with a broken line in the cutting diagrams are to be placed face down on the fabric. The cutting diagrams on the pattern sheet show how the pattern pieces should be placed on the fabric.

The cutting diagrams show the placement of the pattern on the fabric. Fabric I, fabric II and tulle. Cut pieces 1 o 16 from fabric I, pieces 17 to 19 from fabric II. Cut piece 20 from tulle according to the cutting diagram. For a single layer of fabric, the pattern pieces are pinned to the right side. For double layers of fabric, the right sides are facing and the pattern pieces are pinned to the wrong side. The pattern pieces that are shown extending over the fold of the fabric in the cutting diagram should be cut last from a single layer of

fabric.

---

## Step 5

### INTERFACING

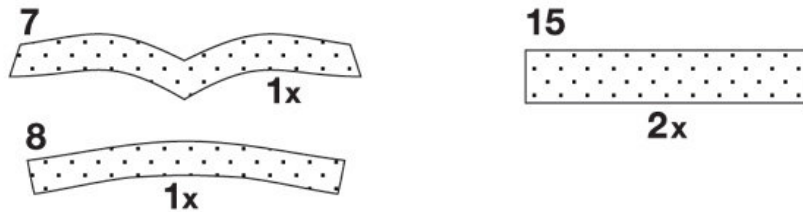

SEAM AND HEMLINE ALLOWANCES are included on an average: 5/8" (1.5 cm) for all edges and stitches. Using BURDA copying paper, transfer the lines and signs of the pattern onto the wrong fabric side. Instructions can be found in the packaging.

#### INTERFACING

Cut the interfacing pieces according to the cutting diagram and press onto the wrong fabric side.

#### Sewing

While sewing, the right fabric sides are facing.

Transfer all lines of the pattern onto the right fabric side using basting stitches

---

## Step 6

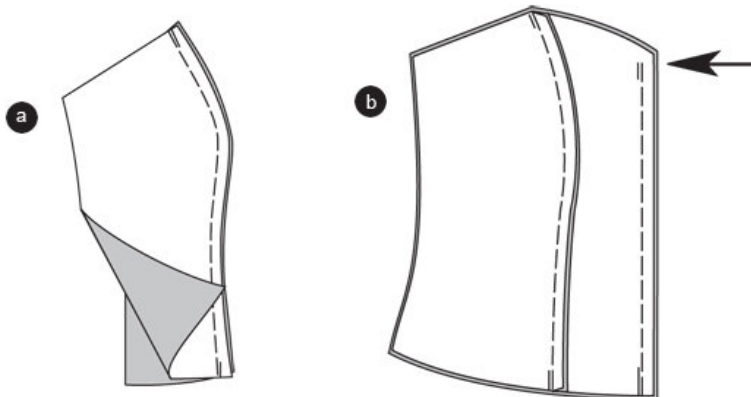

#### SLIP DRESS

Top / princess seams

Position the front side pieces on the front center pieces, right sides facing. Pin the front princess seams (seam 1) and stitch. Stitch the back princess seams the same way (seam 3). Neaten allowances and press, respectively, towards the center front and center back (a).

### Front center seam

Position the front pieces together, right sides facing. Pin the front center seam. Stitch; ending at the seam allowance (arrow). Secure seam ends. Neaten allowances and press apart (b).

### Right side seam

Position the back piece on the front piece, right sides facing. Pin the right side seam (seam 5) and stitch. Neaten allowances and press apart.

---

## Step 7

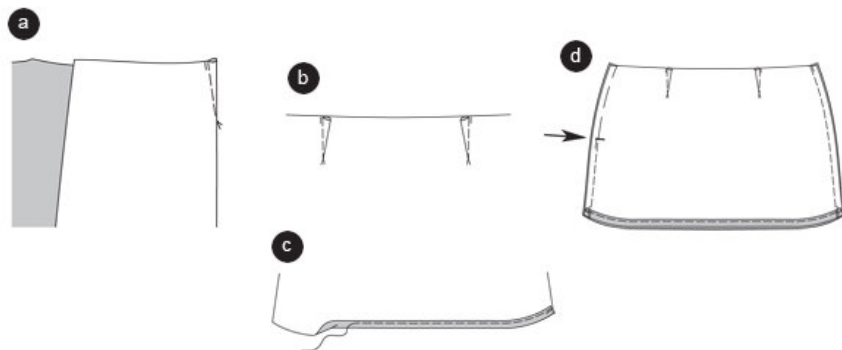

### Skirt

Pin the darts of the front and back skirt panel and stitch to a point (a). Press the darts towards the front and the back center, respectively (b).

Trim the hemline to width of 2 1/4" (0.7 cm), fold inside and press. Topstitch the bottom of the skirt panel 1/2" (0.5 cm) wide, thereby stitching the hemline ©.

### Side seams

Position the front skirt panel on the back skirt panel, right sides facing. Baste the side seams (seam 2). Stitch the right side seam, stitch the left side seam from slit sign (arrow) to the bottom. Secure seam ends. The slit is still basted. Neaten allowances and press apart. Open basting stitches (d).

---

## Step 8

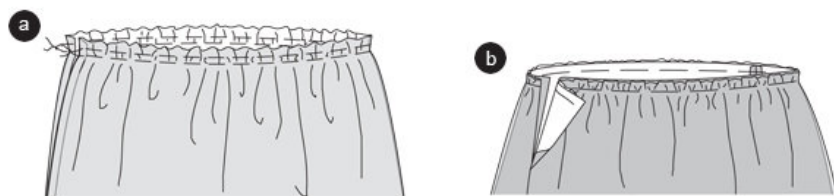

### Tulle skirt

Stitch the tulle pieces together. Note: Leave a 6" (14 cm) long opening on one of the top seams. Secure seam ends. Along the opening, press the allowances to the top.

Stitch two rows of basting stitches at the top skirt edge. Tighten the bobbin thread to the width of the top skirt. Knot threads. Distribute the width equally (a).

Pull the tulle skirt over the top skirt, the wrong side of the tulle skirt faces the right top skirt side. Pin the top edges. The opening allowances are exposed (b).

---

## Step 9

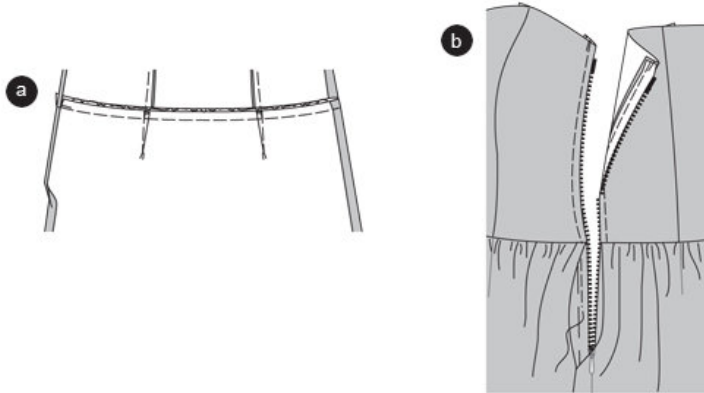

Stitch the skirt

Pin the skirt on the top piece, right sides facing (seam 4). Side seams meet. The darts meet the princess seams. Topstitch the skirt, sandwiching the tulle skirt. Trim allowances, neaten and press inside the top piece (a).

Zipper

Neaten allowances along the opening, fold inside and pin. Press.

Pin the zipper under the opening edge so that the little teeth are hidden. Stitch using a zipper foot, interrupting at the skirt seam and not catching the tulle skirt (b).

---

## Step 10

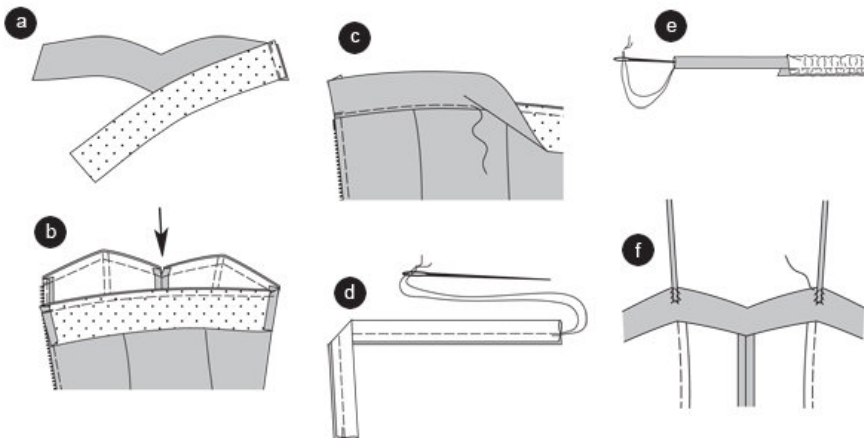

## Facing

Position the back facing on the front facing, right sides facing. Stitch the side seam in an inverted mirror image position, in accordance to the dress seam. (seam 6). Press allowances apart. Neaten the bottom facing edge (a).

Pin the facing on the top dress edge, right sides facing; side seams meet. Fold the side edges inside. Pin the facing and stitch. Trim allowances, snip in the front center (arrow) (b).

Flip the facing up. Press the allowances of top dress edge and facing. Topstitch the facing, enclosing the allowances. Turn the allowances of the top dress and facing to the inside and stitch onto the zipper strap and the seam allowances ©.

Shoulder straps: Fold straps in half lengthwise, right sides facing. Stitch ½" (0.8 cm) along the fold line. Leave the threads long, thread them into a needle and knot (d). Push the needle through the tube (e).

Pin the ends of the shoulder straps under the top dress edge at the princess seams. Adjust the strap length accordingly. Topstitch the shoulder straps on the princess seams or sew by hand.

---

## Step 11

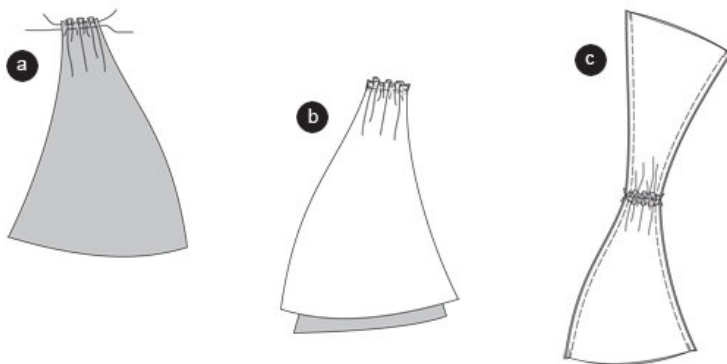

## DRESS

### Top piece / shoulder straps

Double stitch the shoulder straps in two rows of basting stitches along the shoulder edge. Tighten the bobbin threads to 2" (5 cm). Knot threads. Distribute the width equally (a).

### Shoulder seams

Position the front and back shoulder straps together; right sides facing. Pin the shoulder seams (seam 7) and stitch. Press allowances apart, not flattening the ruffles (b).

### Double shoulder straps

Position two straps together, right sides facing; pin the edges and stitch. Turn inside out, position the open edges together, pin. Double stitch the bottom strap edges. Do not tighten the bobbin threads yet ©.

---

## Step 12

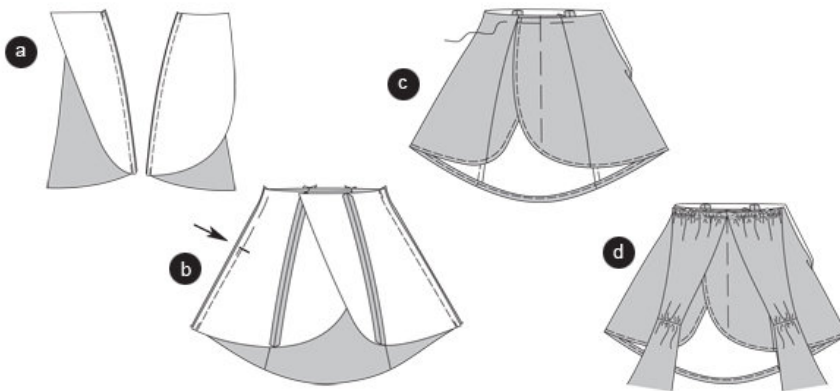

### Skirt / front and back princess seams

Position the front center skirt panels on the front side panels, right sides facing. Pin the front princess seams (seam 8), stitch. Neaten allowances and press apart. Stitch back princess seams (seam 9) (a).

### Side seams / left side slit

Position the front skirt panels on the back skirt panels, right sides facing. Pin the side seams (seam 10). Stitch the right side seam, stitch the left side seam from slit sign (arrow) to the bottom. The slit is basted. Neaten allowances and press apart. Open the basting stitches at the slit. Stitch the hemline (b).

Position the left front skirt panel on the right front skirt panel, the centers meet. Pin the top edges together ©.

### Topstitch the shoulder straps

Tighten the bobbin threads on the front and back strap edges to gather and match the width of the front and back skirt panels. Knot the threads. Distribute the width equally.

Pin the front strap edges on the front skirt panels, right sides facing (seam 11), the straps meet at the front center, the side edges meet the side seam, the skirt edge respectively. The slit allowance overlaps. Stitch the back strap edges on the back skirt panel (seam 12). Trim allowances, neaten and press inside the skirt (d).

---

## Step 13

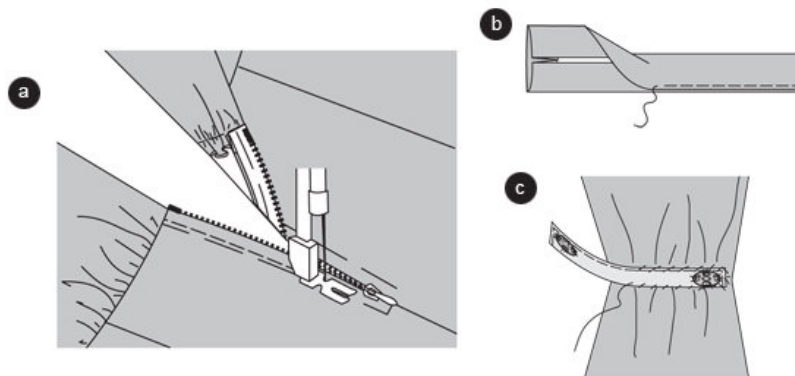

## Zipper

Fold the allowances of the slit inside. Pin the zipper under the slit edges so that the little teeth are hidden. Stitch using a zipper foot (a).

Fold and press the loops for the shoulder straps along the narrow sides, then press along the long sides towards the center. Fold the loop in half and press. Stitch the edges together. Stitch the loops on the wrong side of the shoulder seams. Sew the press studs on the loop ends ©.

---

## Step 14

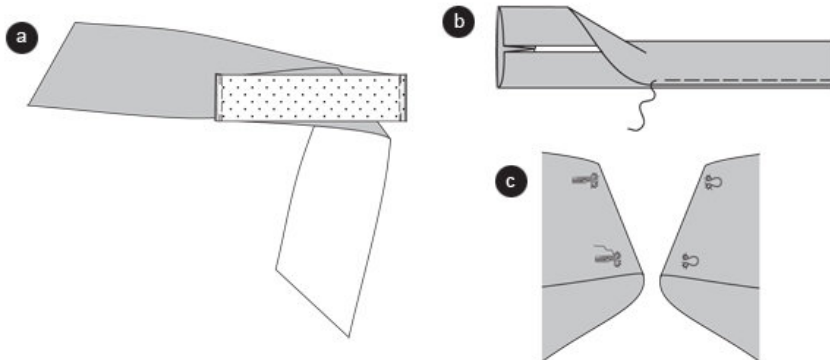

## Belt

Stitch the straps on the belt, right sides facing (seam 13). Press allowances apart (a).

Position the pieces together, right sides facing. Stitch the edges, leave an opening for turning. Secure seam ends. Turn the belt. Pin the edges, press (b). Sew HOOKS and EYES on x on the inner/wrong side of the belt ©. Pull the dress over the slip dress, trim the tulle frills to a visible length of 3" (8 cm) under the dress.

---

**BurdaStyle**

Sibylle