

Sabrina

By: burdastyle

<http://www.burdastyle.com/projects/sabrina>



This little outfit is the perfect in between season piece. I like wearing it with a turtleneck or a little cardigan if it is too cold, otherwise just bare for warmer times. The pleats are created so that if made in a lighter but stiffer material, the skirt will puff slightly. Try it in seersucker for the spring or, like our example, a colorful

plaid wool which is perfect for late winter/early spring days.

Materials

Plaid wool, big plastic buttons, zipper

Step 1

**burda Download-Pattern
Dress 6008 - Instructions**

 average close fitting

burda sizes	55 ins / 140 cm						
	32	34	36	38	40	42	44
yds	2	2	2	2	2	2	2
m	1.80	1.80	1.80	1.80	1.80	1.80	1.80
	→	→	→	→	→	→	→

→ with nap

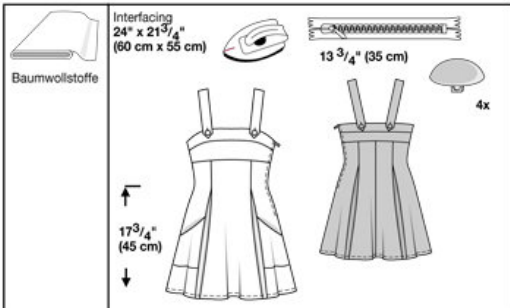

Interfacing
24" x 21³/₄"
(60 cm x 55 cm)

13³/₄" (35 cm)

4x

17³/₄"
(45 cm)

right side

wrong side

interfacing

lining

batting

Patternpieces:

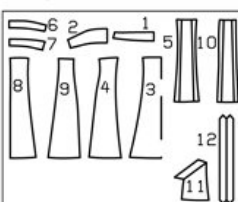

PATTERN PIECES

- 1 Front neckline placket 2x
- 2 Front yoke 2x
- 3 Front center piece 1x
- 4 Front side piece 2x
- 5 Front piece pleated 2x
- 6 Back neckline placket 2x
- 7 Back yoke 2x
- 8 Back center piece 2x
- 9 Back side piece 2x
- 10 Back piece pleated 2x
- 11 Pocket 2x
- 12 Straps 2x

Fabrics: Cotton fabrics

Step 2



The patterns can be printed out at the copy shop. If you decide to print them at home, follow the instructions: Paper cut for ANSI A (German DIN A4) prints: The patterns are printed out on 25 sheets with a thin frame. Wait, until all sheets are printed out. Arrange the sheets so that they fit together (see extra page with the overview of the prints). Cut off the single sheets on the upper and right edge along the thin frame lines. Begin with the left lower sheet and then glue the parts in the frame lines together precisely.

Step 3

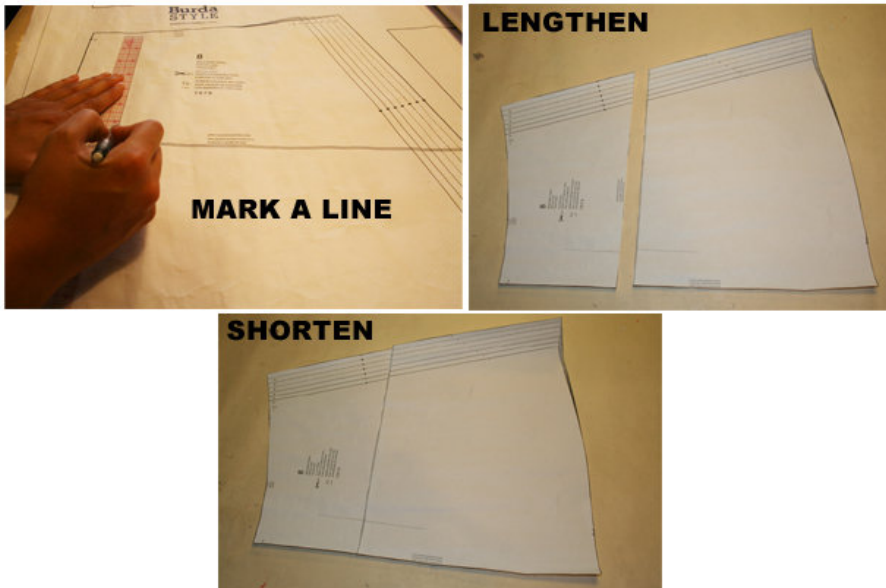

ADJUST PATTERN SIZES

Select your size according to the Burda-dimension table: Dresses, blouses, jackets and coats according to the bust size, trousers and skirts according to the hip width. Change the pattern if necessary, to fit your measurements if they deviate from the Burda-dimension table. Cut out the pattern according to your size. Refer to our "Adjust patterns for mixed sizes" technique

LENGTHENING OR SHORTENING THE PATTERN PIECES ACCORDING TO YOUR SIZE

Our pattern is calculated for a height of 5â€ 6â€ (168 cm). If you are taller or shorter, you may adjust the pattern to fit your size. Choose your size at the lines marked “lengthen or shorten here”. Thus the proper fit is preserved. Make sure that you adjust all pieces of one pattern by the same amount at the same lines.

How to lengthen and shorten pattern pieces:

Cut the pattern pieces along the marked lines.

To lengthen, slide the two halves of the pattern piece as far apart as necessary.

To shorten, overlap the two halves of the pattern piece as far as necessary. Even out the side edges.

Step 4

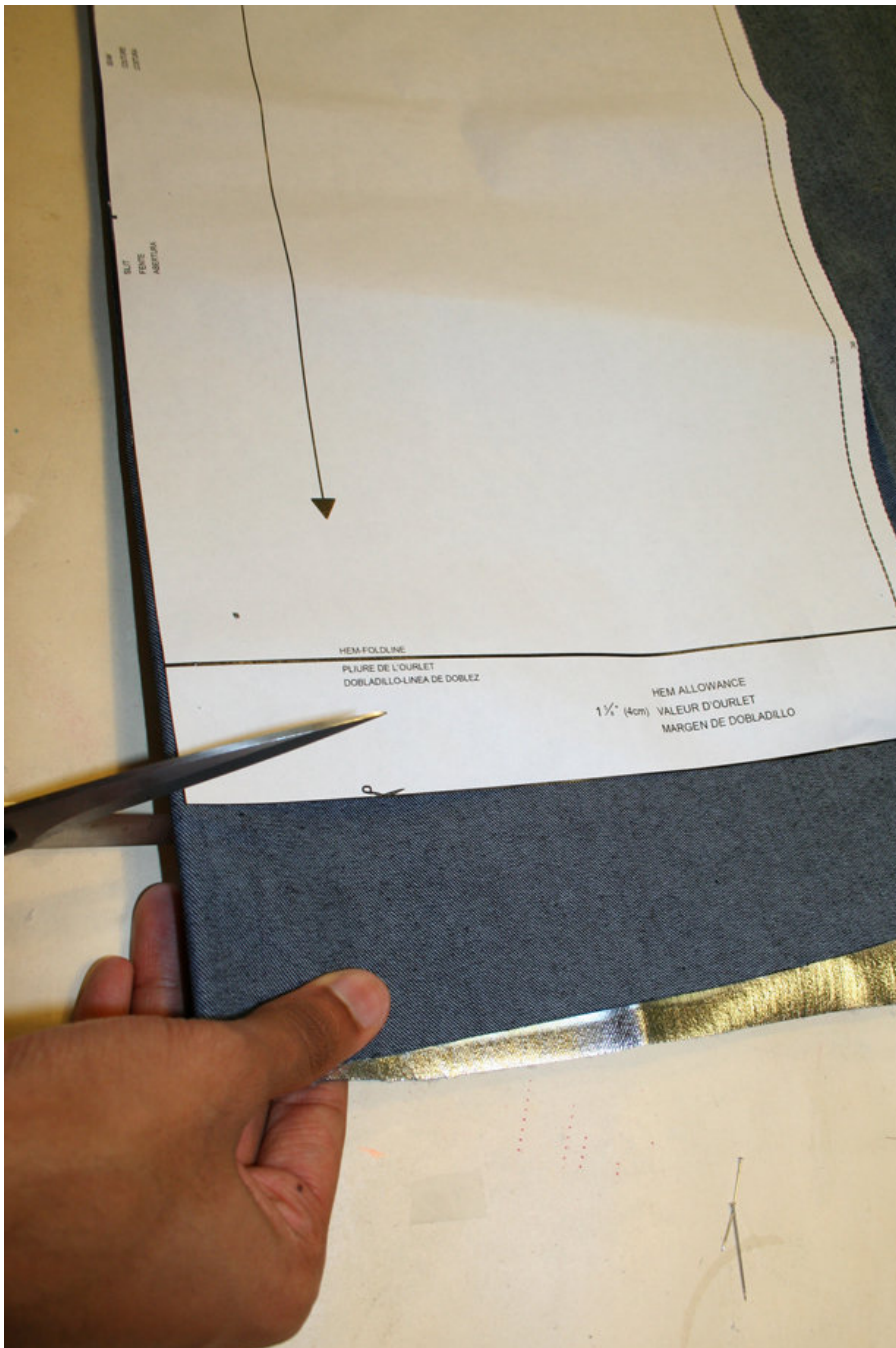

CUTTING OUT

FOLD () means: here is the center of a pattern piece but never a cut edge or a seam. The piece should be cut double, with the fold line forming the center line.

Pattern pieces that are outlined with a broken line in the cutting diagrams are to be placed face down on the fabric.

The cutting diagrams on the pattern sheet show how the pattern pieces should be placed on the fabric.

The cutting diagrams show the placement of the pattern on the fabric

For a single layer of fabric, the pattern pieces are pinned to the right side. For double layers of fabric, the right sides are facing and the pattern pieces are pinned to the left side. The pattern pieces that are shown in the cutting diagram, extending over the fold of the fabric, should be cut last from a single layer of fabric.

Step 5

INTERFACING

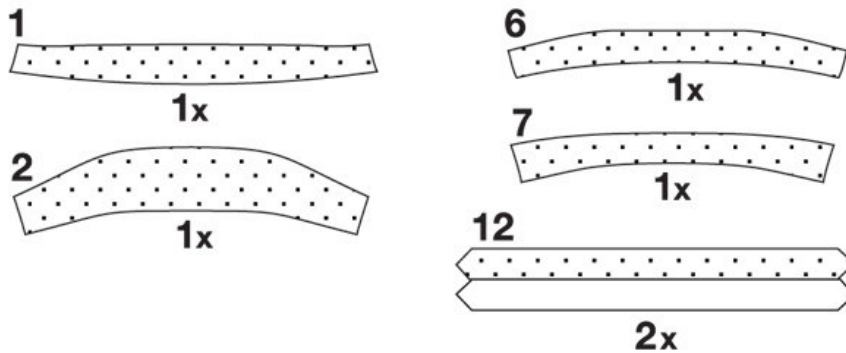

SEAM AND HEMLINE ALLOWANCES are included on an average:

5/8" (1.5 cm) for all edges and stitches.

Using burda copying paper transfer the lines and signs of the pattern onto the left fabric side. You will find instructions in the packaging.

INTERFACING

Cut out the interfacing according to the drawing and press onto the left fabric side.

Sewing

While sewing the right fabric sides are facing. Transfer all lines of the pattern onto the the right fabric side using basting stitches.

Step 6

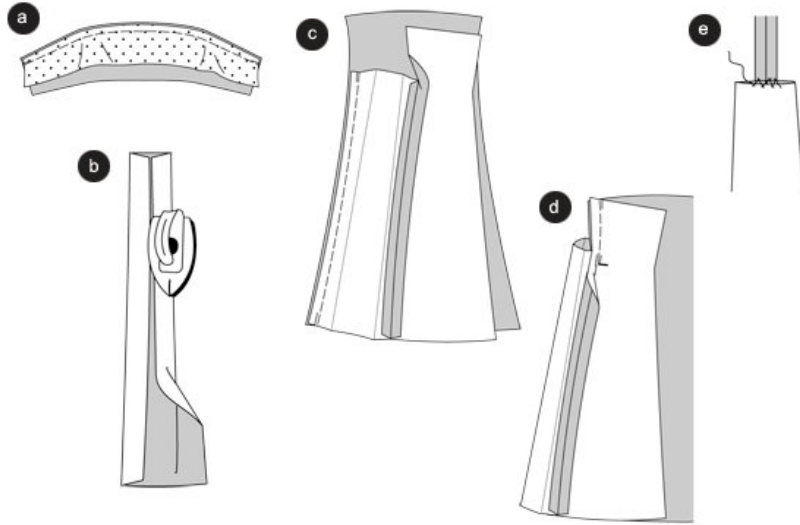

Top part / princess seams

Baste the front placket including the interfacing onto the front yoke including the interfacing, the right fabric sides are facing (seam 1), and stitch (a).

Stitch the back placket including interfacing onto the back yoke (seam 6). Trim the allowances and press them apart.

Skirt panels / pleats

Neaten the upper edge of the pleated pieces. Fold the pleated pieces along the marked FOLD LINE inside and press, right side inside (b).

Baste the front pleated pieces onto the front center piece and the side front piece, the right sides are facing (seam 2). Stitch seams. Neaten allowances and press apart ©.

Place the side front piece onto the front center piece, the right sides are facing. Baste the princess seams from the top to the cross line (seam 4) and stitch. Trim the allowances and press apart (d). Close the pleats on the top part, and stitch the pleated pieces onto the allowances of the princess seams (e), for that you use a herringbone stitch.

Back center seam: Position the back center pieces on top of each other, the right sides facing. Stitch center seam. Trim allowances and press apart. Stitch the back pleated pieces onto the back center and side pieces (seam 7 and 8).

Step 7

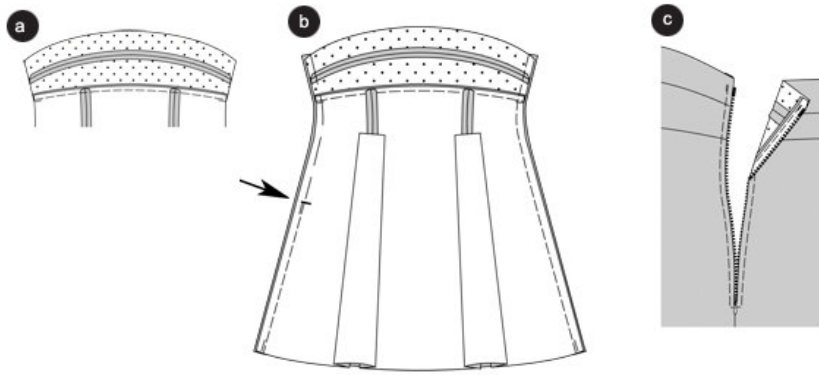

Stitch the back princess seams according to the text and drawing 4 (seam 9). Press the pleats (outer / exposed pleat edges) in a way that the allowances are hidden inside the edge. Stitch the skirt panels.

Baste the front yoke onto the front piece (seam 5), the right sides are facing, and stitch. Trim allowances and press them inside the yoke. Stitch the back yoke in the same way onto the back piece (seam 10) (a).

Side seams

Position the front piece onto the back piece, the right sides are facing. Baste the side seam (seam 11); the cross seams meet. Stitch the right side seam. Stitch the left side seam from the slit sign to the bottom. Secure seam ends. Leave the slit still basted. Neaten allowances and press apart. Open the basting stitches at the slit (b).

Baste the zipper under the slit edges, so that the little zipper teeth are covered. Stitch the zipper using the zipper foot ©.

Step 8

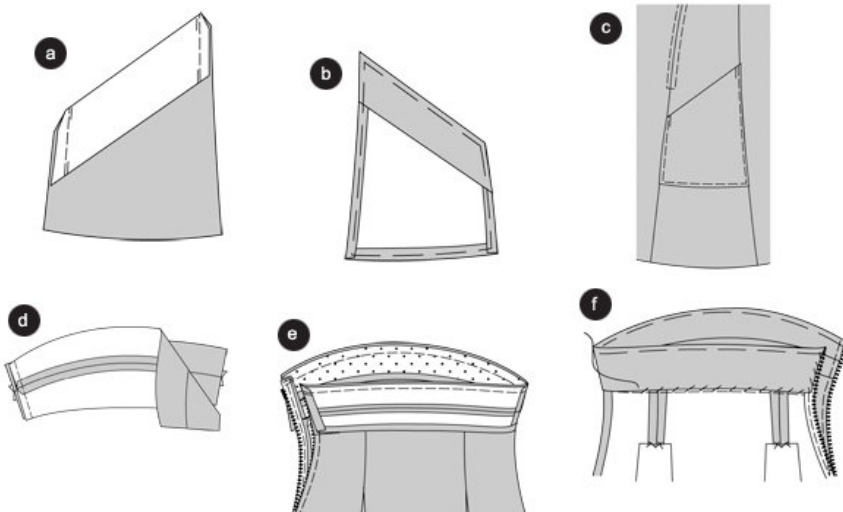

Pockets
Neaten edges

Fold the placket along the FOLD LINE to the outside, pin. Stitch the narrow edges onto the pockets. Cut the corners bias (a).

Fold the placket and allowances inside, baste and press (b).

Baste the pockets, that they meet the seam line onto the side front pieces; the front edges meet the pleat seams. Stitch the pockets narrowly; the pleats are folded in place. Double the top of the jumper (stitch interfacing onto the left side of the top piece). Stitch the placket onto the front and back yoke. Trim allowances and press apart ©.

Position the front yoke onto the back yoke, the right sides facing. Stitch the right side seams like a mirror image of the jumper. Press the allowances apart. Press the allowances of the bottom edge inside (d). Baste the placket onto the upper jumper edge, the right sides facing. The side seams meet. Fold the narrow edges along the zipper inside. Stitch the placket. Trim allowances (e).

Fold the placket inside. Baste the upper edges, press. Baste the bottom placket edge onto the seam. Baste the side edges onto the zipper straps. Sew the edges by hand (f).

Step 9

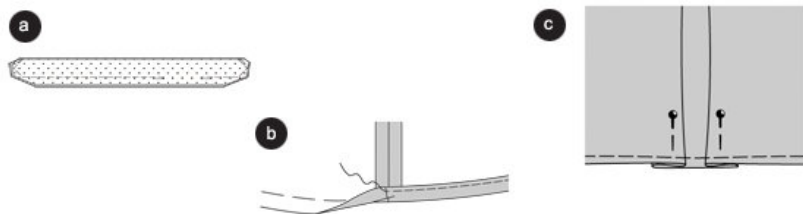

Straps

Fold the straps lengthwise, right side inside. Stitch the edges on top of each other according to the drawing; an opening needs to be left to turn it over. Turn it inside out. Then baste the edges, press and stitch narrowly, thereby stitching over the seam opening. Adjust the strap length and button position when trying the jumper on. Apply a BUTTONHOLE onto the strap ends. Sew the BUTTONS onto the front and back placket. Button the straps (a).

Hemline

Neaten the hemline, fold inside, press. Pin the pleats at the hem that meets the fold line. Press (b). Stitch the hemline approximately 1/2" (1 cm) from the edge, thereby also stitching the pleats ©.

BurdaStyle

Sabrina