

# Suspender Pants 04/2012

By: burda style magazine

<http://www.burdastyle.com/projects/suspender-pants-042012>

---



These boy's pants are so adorable with the button suspenders. Our instructions include a diagram for drafting and making the suspender pieces yourself. Our version is made from a striped linen but a more durable fabric like denim can also be used.

## Materials

Lengthwise striped linen, Width: 150 cm (59 ins) Length: 0.80 0.80 0.85 0.85 0.90 m (7/8 7/8 1 1 1 yd) A small piece of suede leather Elastic, 2.5 cm (1 in) wide and 0.35 m (1/2 yd) long Elastic, 2 cm (3/4 in) wide

and 0.15 m (1/4 yd) long 8 buttons Textile glue (e. g. Rudolfix, G termann Klebenaht HT 2)

---

## Step 1 — Preparations



This pattern is printed on 8.5 × 11 sheets of plain paper. Do not scale or center pages before printing. Wait until all sheets are printed out before beginning to tape them together. **Do not cut out pattern pieces yet**— Arrange the sheets on a large, hard, flat surface so that they fit together, matching up like numbers and letters (i.e. 6A to 6A). To tape pattern together, fold under the margin of one piece (6A) and tape right against the line of it's matching number/letter (6A).

Trace the pattern pieces from the pattern sheet following the lines and markings for the correct size and the correct style (140). (This pattern also includes pattern pieces, lines and markings for style 141 that should be ignored.) Trace the pocket piece from piece 1 as a separate pattern piece it is the same for all sizes.

See pattern pieces for centre back piece (A) and loop (B) printed in grey on next page. Trace pattern pieces.

**burda style magazine pattern do not have seam allowance included.**

Seam and hem allowances to be added: Seams and edges 1.5 cm (5/8 in), hem 4 cm (15/8 ins).

---

## Step 2 — Cutting Out

### Pattern pieces 1 to 3

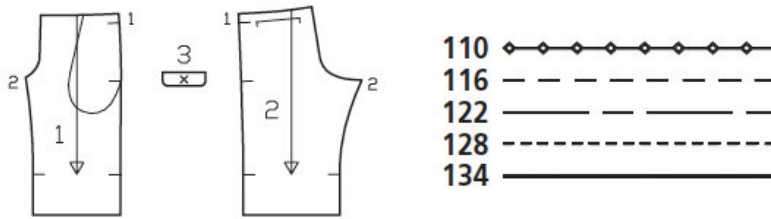

Cut the pieces as in this diagram with a fabric width of 150 cm

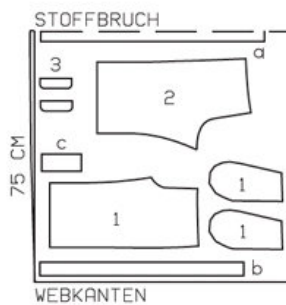

Stoffbruch = Fabric Fold  
Webkanten = Selvage

Linen:

- 1 front trouser piece 2x
- pocket piece 4x
- 2 back trouser piece 2x
- 3 back flap 4x

Also draft and cut the following pattern pieces, not included in the pattern sheet.

a) waistband, length: 67 67.5 70 72.5 75 cm (26 1/2 26 5/8 27 3/4 28 5/8 29 3/4 ins)  
width: 6 cm (2 1/2 ins), finished width 3 cm (1 1/4 ins)

b) 2 braces/suspenders, length: 61 63 66 69 72 cm (24 24 3/4 26 27 1/4 28 1/2 ins)  
width: 4 cm (15/8 ins) wide, finished width 2 cm (3/4 in)

c) back braces/suspenders piece, length: 12 cm (4 3/4 ins)  
width: 5 cm (2 ins) wide, finished width 2.5 cm (1 in)

---

## Step 3 — Suspender Suede Pieces

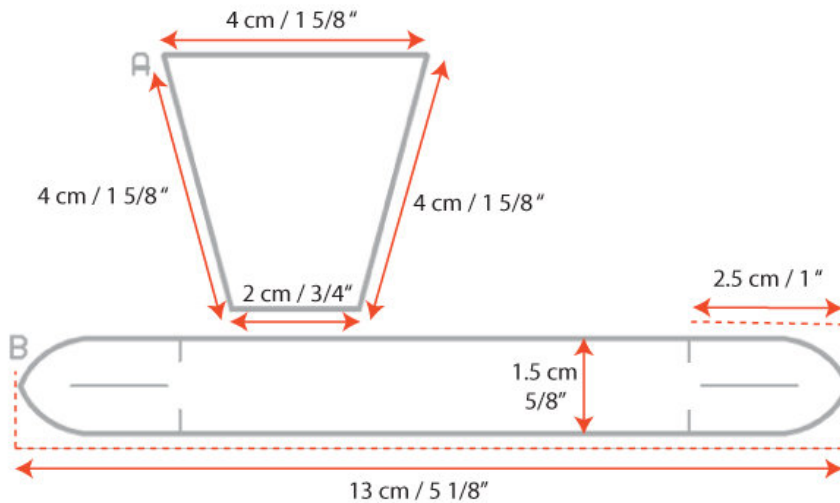

Refer to above diagram on how to draft the suede pieces.

For piece A draw a trapezoid according to the above measurements.

For piece B draw a rectangle 13cm (5 1/8") long, and 1.5cm (5/8") wide. Make marks 2.5cm (1") from the edges. Refer to the diagram and round the corners of the pieces.

A centre back piece 2x

B loop 3x

Cut piece A once with 5 mm (3/16 in) wide allowances and once without allowances.

Cut pieces B with out allowances.

---

## Step 4 — Sewing

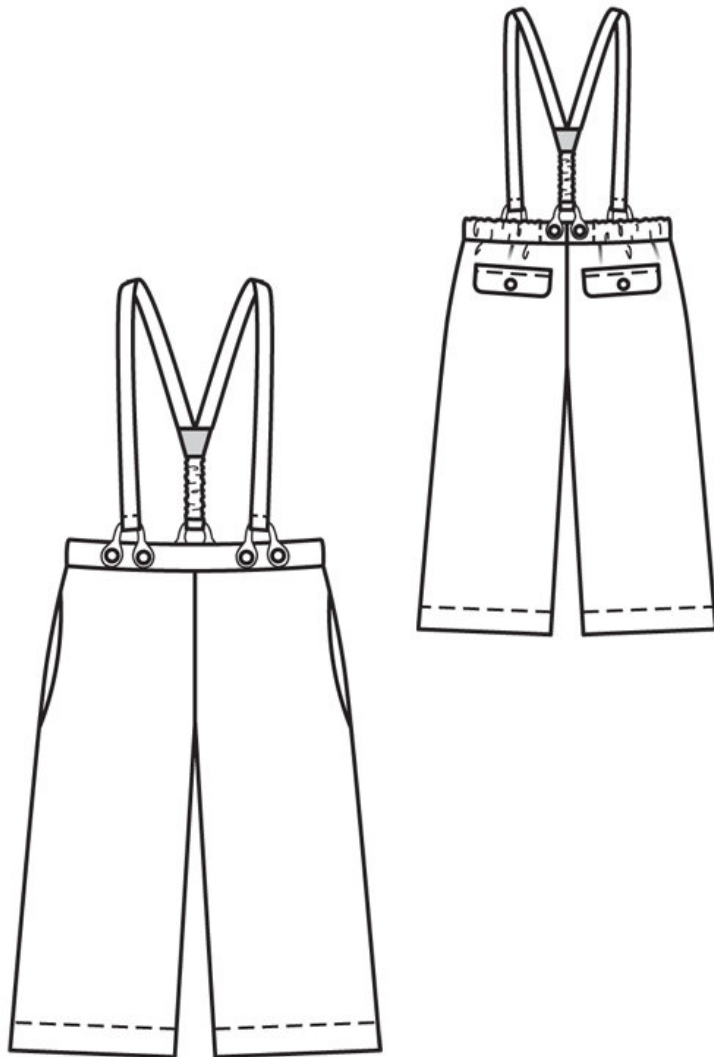

Stitch pairs of flap pieces right sides together, leaving joining edge open. Turn right side out. Topstitch close to edges. Stitch flaps to back trousers, along joining lines. Press flaps down and stitch again 5 mm (3/16 in) from joining edges. Sew flaps to trousers, with one button each.

Stitch side seams, not stitching across pocket openings.

Inseam pockets, Work from inside to pin pocket pieces to seam allowances of pocket opening edges, right sides facing. Stitch pockets in place, directly along marked seam lines. Above pocket openings, stitch pocket pieces in place close to seams. Press pocket pieces forward and stitch together. Baste upper pocket edges in place.

Stitch inside leg seams. Pull one trousers leg into the other, right sides facing. Stitch centre front and back seams as continuous seam. Press seam open, from upper edge to beginning of curve. Do not press allowances flat along curve.

Stitch centre back seam of waistband. Stitch waistband to upper edge of trousers. Press allowances of joining seam and of other long waistband edge onto waistband. Fold waistband in half length wise. Pin inside edge in

place. On waistband, mark ends of elastic casing, above each side seam and 3 cm (1 1/4 ins) from centre back seam. Topstitch waistband close to joining seam, between markings, catching inside edge.

Cut the 2.5 cm (1 in) wide elastic into two equal pieces. Pull elastic into waistband and stitch at markings for a finished gathered length of 11 1/2 12 1/2 13 cm (4 3/8 4 1/2 4 3/4 5 1/4 ins). Stitch remaining inside waistband edge in place.

Press hem allowances to inside, turn in to 3 cm (1 1/4 ins) wide, and stitch.

Braces/suspenders: Fold braces and back braces pieces lengthwise. Stitch long edges together. Turn right side out and press. Topstitch braces close to edges. Pull 2 cm (3/4 in) wide elastic into back braces piece. Stitch one end of elastic to top end of braces piece. Pull second end down, out the bottom, and stitch to braces piece, 3 cm (1 1/4 ins) above bottom end finished length of elastic casing = 7 cm (2 3/4 ins).

Overlap back ends of braces at an angle and glue to wider upper edge of centre back piece without allowance (on wrong side of leather), approx. 1 cm (3/8 in) wide. Glue back braces piece to lower edge of centre piece. Glue second centre piece to first piece, wrong sides facing, with edges extending evenly. Topstitch close to edges of centre piece without allowance and trim away extending allowances of other piece. Turn front ends of braces and bottom end of back piece to inside, 3 cm (1 1/4 ins) wide, turn edge under, 1 cm (3/8 in) wide, and stitch.

Cut buttonholes in loop pieces as marked. Fold loops in half lengthwise and stitch edges together between markings. Pull loops into ends of braces. Sew buttons to centre of each front trouser piece and to waistband, on each side of centre back seam, spacing between buttons is 4 cm (1 5/8 ins). Button loops of braces to trousers.

---

**BurdaStyle**

Suspender Pants 04/2012