

# Diana

By: burdastyle

<http://www.burdastyle.com/projects/diana>

---



This fun and easy bag is just what everyone needs : it's quick and easy to sew, and it's reversible, giving you two fashion options in one. Choose fun fabrics—we used leather, embossed leather, and a fun denim print as lining—and you'll never get bored with your groovy new bag.

# Materials

leather, embossed leather, printed denim

---

## Step 1

**burda Download-Pattern**  
**Tasche 8235 - Instructions**

 **very easy**

		45 ins / 114 cm	55 ins / 140 cm
I	yds	1/4	1/4
	m	0.50	0.50
II	yds	1/2	1/2
	m	0.40	0.40

\* without nap





Jeansstoffe,  
Baumwollstoffe,  
Microfaserstoffe

Interfacing  
30 x 35 cm







 right side

 wrong side

 interfacing

 lining

 batting

**Patternpieces:**

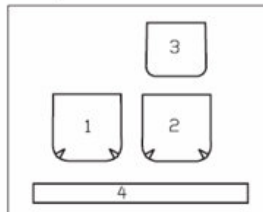

### PATTERN

- A 1 Front bag piece 1x
- A 2 Back bag piece
- A 3 Cover 1x
- A 4 Handle 1x

FABRICS: Jeans, cotton or micro fiber fabrics

---

## Step 2



The patterns can be printed out at the copy shop. If you decide to print them at home, follow the instructions:  
Paper cut for ANSI A (German DIN A4) prints:  
The patterns are printed out on 14 sheets with a thin frame. Wait until all sheets are printed out. Arrange the sheets so that they fit together (see additional page with the overview of the prints). Fold the single sheets on the upper and right edge along the thin frame lines. Begin with the left lower sheet and then tape the frame lines together precisely.

---

### Step 3

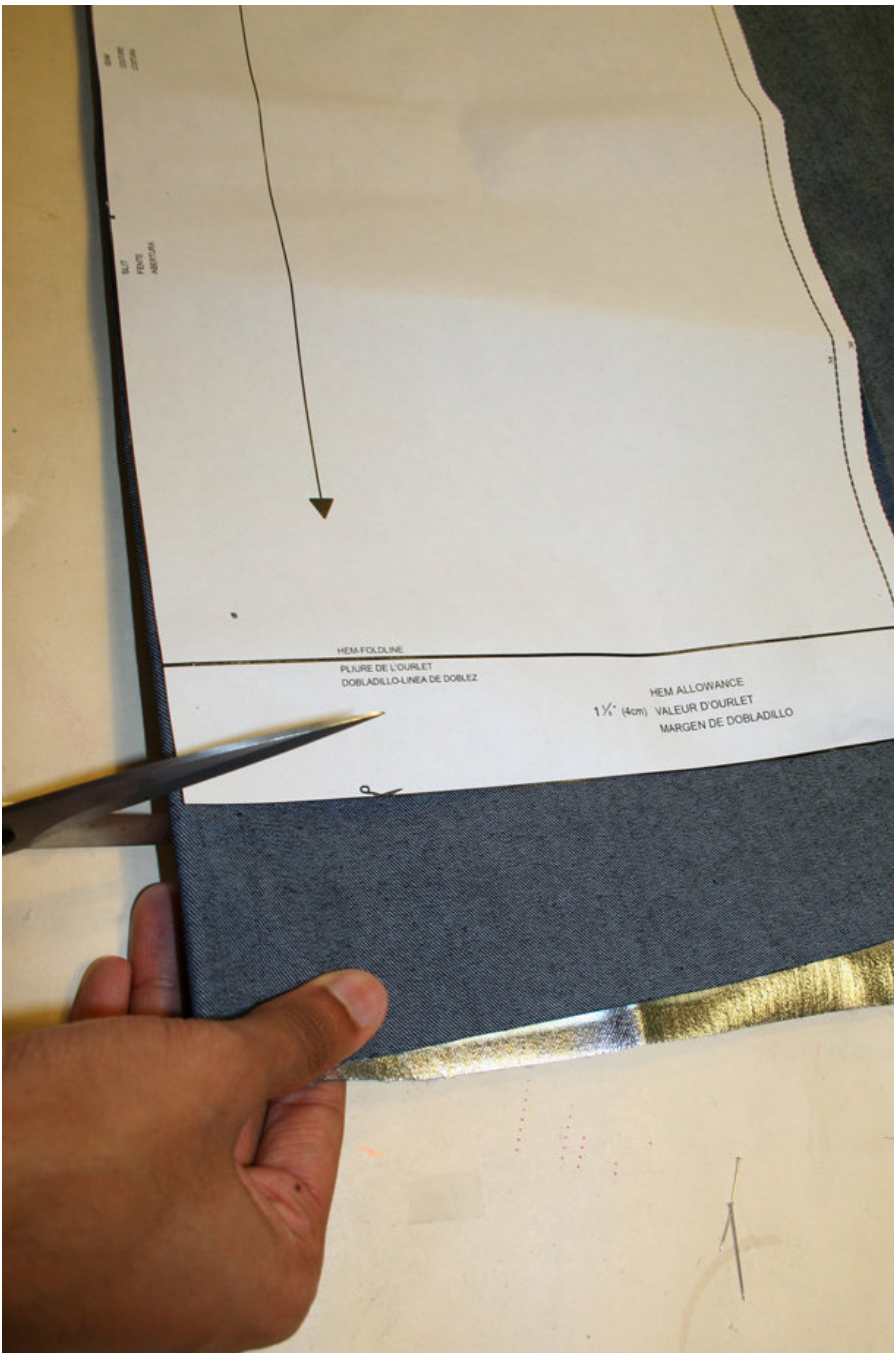

## CUTTING OUT

FOLD (â’ â’ â’ â’ ) means: Cut on the fold, the fold being the center of the pattern piece, but never a cut edge or seam. The piece should be cut double, with the fold line forming the center line. Pattern pieces that are outlined with a broken line in the cutting diagrams are to be placed face down on the fabric. The cutting diagrams on the pattern sheet show how the pattern pieces should be placed on the fabric.

The cutting diagrams show the placement of the pattern on the fabric.

Use a single layer of fabric to cut out the fabric pieces. The pattern pieces are pinned to the right side of the fabric. Cut out the fabric pieces along the edges of the pattern pieces.

Note: The bag will be lined with a contrasting fabric. So, the bag can be used from both sides.

Fabric I (fabric for the outside of the bag)

Fabric II (lining fabric): Cut the pieces 1 to 3 each 1x from fabric I and from fabric II, piece 4 (handle) only 1x from fabric I (fabric for the outside of the bag). See the cutting diagrams.

---

## Step 4

### INTERFACING

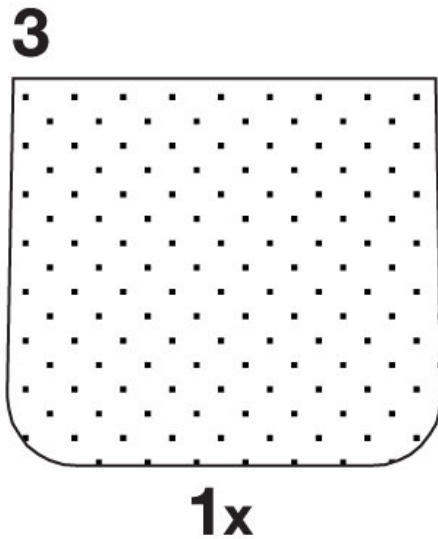

#### INTERFACING

Cut out the interfacing according to the cutting diagram. Then press the interfacing piece onto the wrong side of the fabric.

#### Sewing

While sewing, the right sides of the fabric are facing.

Transfer all lines of the pattern onto the right side of the fabric .

ALLOWANCES are included on an average.  $\hat{\wedge}$  (1 cm) for all edges and stitches. Using BURDA copying paper, transfer the lines and signs of the pattern onto the wrong side of the fabric. Instructions can be found in the packaging.

---

## Step 5

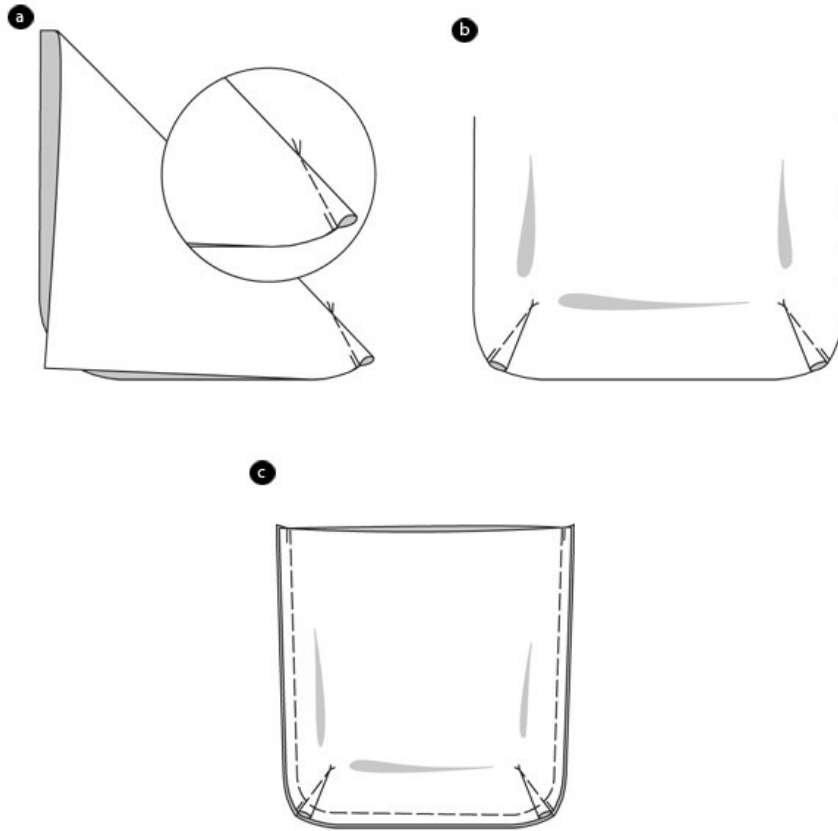

#### BAG

Position and stitch the outer bag pieces (fabric I) together.

#### DARTS

Pin the darts of the front and back bag piece. (a) Then stitch the darts, starting at the wider part and sewing to the point. Knot thread ends. Press the darts (b).

#### BAG PIECES

Position the front bag pieces on the back piece, right sides facing. The darts meet. Pin the side and bottom edge and stitch. Secure the seam ends. Press the allowances of the side edges apart until you reach the curve. Stitch the bag pieces of the lining fabric (fabric II) in the same way. ©

## Step 6

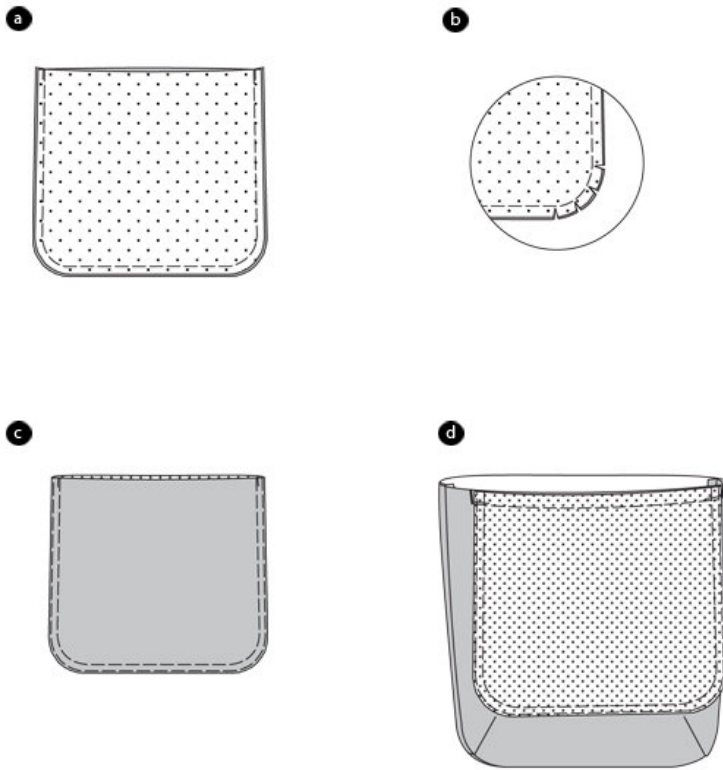

## BAG COVER

Position the cover pieces together, right sides facing. Stitch the side and bottom edges according to the drawing. (a) Trim the allowances. Snip in the curves (b).

Turn the cover inside out. Pin the edges and press. Topstitch the side and bottom edges narrowly,  $\hat{A}\frac{1}{4}\hat{a}$ ' (0.7 cm) wide. Note: You may use a thread in a contrasting color. ©

Position the cover onto the top bag edge between the cross lines (seam 1), right sides facing. Stitch the cover. Secure the seam ends. (d)

## Step 7

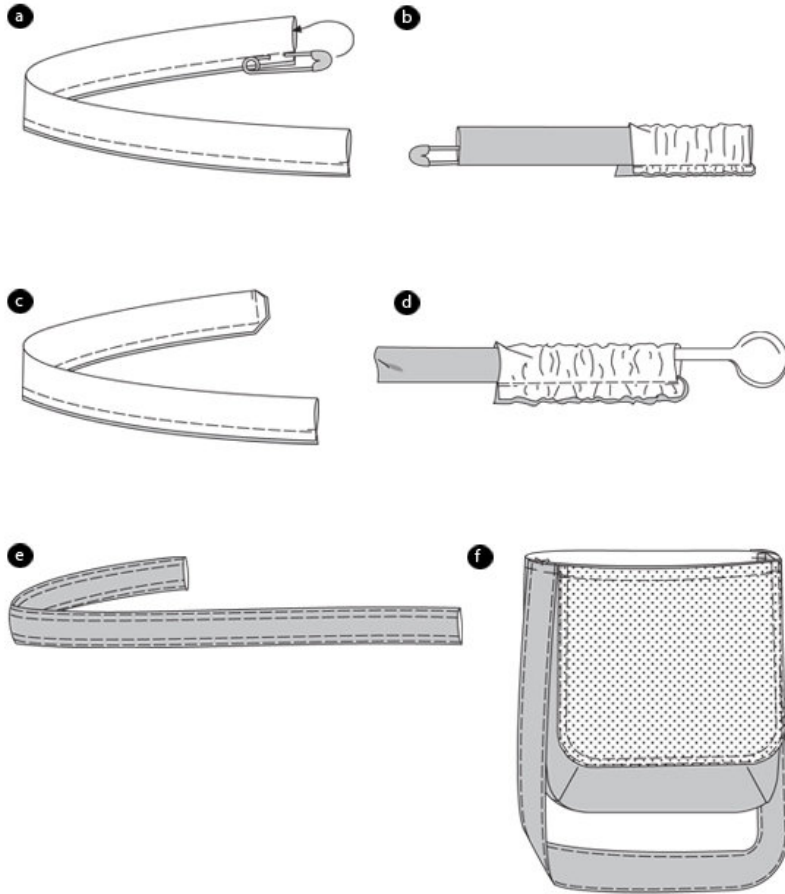

## HANDLE

Fold the handle along the fold line, right sides facing. Stitch the long edges together. Turn the handle. (a)  
 Note: using a big safety pin you can easily turn the handle though pulling the needle. (b)

Note: If you don't have a safety pin, a ruler or stick will also work. Stitch the edge of one handle end. ©  
 Then push the end inside the handle and use the tool to push the whole length through (d). Cut the previously stitched end of the handle open again. The handle ends will be enclosed later.

Pin the handle and press. Stitch the long edges narrowly  $\hat{A}1/4\hat{A}$ ' (0.7 cm) wide. (e)

Pin the handle ends between the marked cross lines, next to the cover, onto the narrow top bag edges. Stitch. (f)

---

## Step 8

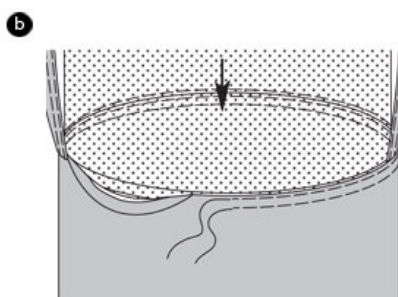
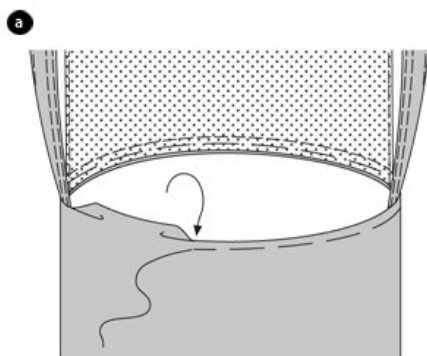

#### TOP BAG EDGES

All around the top bag edge, fold the allowances to the inside and baste. Handle and cover are flipped up. (a)

#### LINE THE BAG

All around the top bag edge, fold the allowances of the inner bag (lining fabric) to the inside and baste.

Move the lined bag piece inside the outer bag piece, the wrong sides are facing. The side seams meet. The top edges meet. Topstitch the edge narrowly  $\hat{A}\frac{1}{4}\hat{a}$ ' (0.7 cm) wide. (b)

---

**BurdaStyle**

Diana