

Marilyn Trousers

By: BurdaStyle

<http://www.burdastyle.com/projects/marilyn-trousers>



Gone are the days of rear-end revealing low-risers making room for classy high waist trousers. Though this look is not for everyone, high waisted trousers can be waist defining, leg lengthening and fun to wear. We paired our sage green wool-crepe trousers with a tight fitting leotard with plunging back and black heels. Our Marilyn trouser is about 38" (98 cm.) long. A slight variation on this look could be created from our Bella pattern, a high waist trouser with a flared leg.

Materials

Size 34 - 46 requires 1 3/4 - 2 1/8 yards (1,50 - 1,90 meters) of gabardine, light-weight wool or silk material, 7" (18 cm.) zipper, 10" (90 x 25 cm.) interfacing, hook & eye closure.

Step 1 — PATTERN

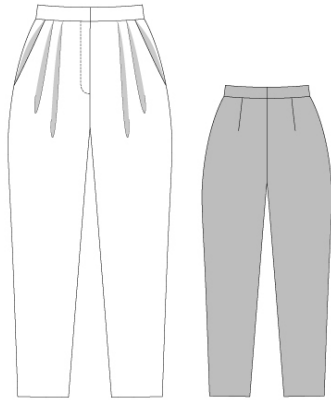

PATTERN

- 1 Front pant piece 2x
- 2 Pocket pouch 2x
- 3 Hip yoke piece 2x
- 4 Back pant piece 2x
- 5 Waistband 2x

Fabrics: Cotton fabrics, gabardine fabrics

The patterns can be printed out at the copy shop. If you decide to print them at home, follow the instructions:

Paper cut for ANSI A (German DIN A4) prints:

The patterns are printed out on 40 sheets with a thin frame. Wait, until all sheets are printed out. Arrange the sheets so that they fit together (see extra page with the overview of the prints). Fold the single sheets on the upper and right edge along the thin frame lines. Begin with the left lower sheet and then tape the frame lines together precisely.

Step 2 — ADJUST PATTERN SIZES

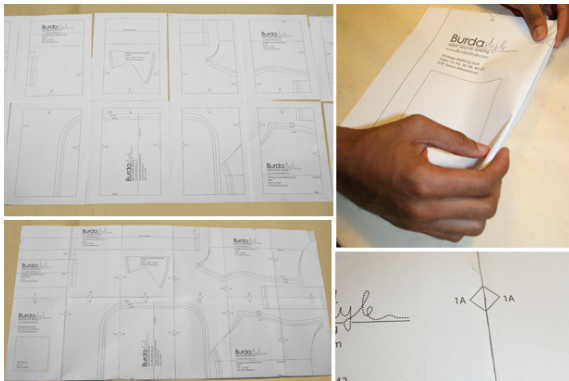

ADJUST PATTERN SIZES

Select your size according to the Burda-dimension table: dresses, blouses, jackets and coats according to the bust size, trousers and skirts according to the hip width. Change the pattern to fit your measurements if they deviate from the Burda-size chart. Cut out the pattern pieces 1 to 5 for the pant according to your size.

Sizes 4 to 14 (EU 36 to 46)

On piece 1, mark the lines for the zipper with the same space to the center front as for size 2 (EU 34).

Refer to our “Adjust patterns for mixed sizes” technique.

LENGTHENING OR SHORTENING THE PATTERN PIECES

Our pattern is calculated for a height of 5’6” (168 cm). If you are taller or shorter, you can adjust the pattern pieces along the lines marked “lengthen or shorten here”. This way the proper fit is maintained. Always adjust all pattern pieces along the same line to the same degree.

How to lengthen and shorten pattern pieces:

Cut the pattern pieces along the marked lines

To lengthen, slide the two halves of the pattern piece as far apart as necessary.

To shorten, overlap the two halves of the pattern piece as far as necessary. Blend the side edges.

Step 3 — CUTTING OUT | FOLD (— — — —)

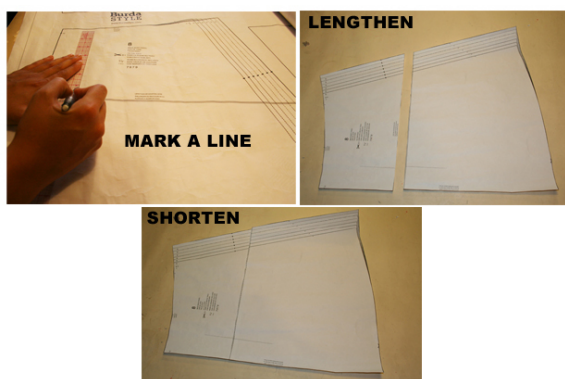

CUTTING OUT

FOLD (— — — —) means: Cut on the fold, the fold being the center of the pattern piece, but never a cut edge or seam. The piece should be cut double, with the fold line forming the center line. Pattern pieces that are outlined with a broken line in the cutting diagrams are to be placed face down on the fabric. The cutting diagrams on the pattern sheet show how the pattern pieces should be placed on the fabric.

The cutting diagrams show the placement of the pattern on the fabric.

For a single layer of fabric, the pattern pieces are pinned to the right side. For double layers of fabric, the right sides are facing and the pattern pieces are pinned to the wrong side. The pattern pieces that are shown extending over the fold of the fabric in the cutting diagram should be cut last from a single layer of fabric.

Step 4 — SEAM AND HEMLINE ALLOWANCES | INTERFACING

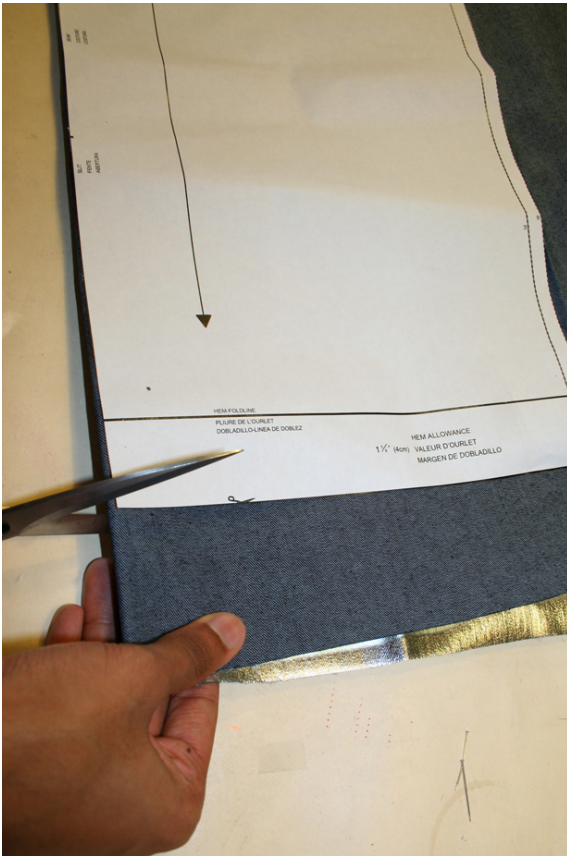

SEAM AND HEMLINE ALLOWANCES are included on an average:

1 5/8" (4 cm) for hem, 5/8" (1.5 cm) for all edges and stitches. Using BURDA copying paper, transfer the lines and signs of the pattern onto the wrong side of the fabric. Instructions can be found in the packaging.

INTERFACING

Cut out the interfacing pieces and press onto the wrong side of the fabric.

Sewing

While sewing, the right sides of the fabric are facing.

Transfer all lines of the pattern onto the right side of the fabric using chalk.

Step 5 — PANTS | DARTS | PANT'S PLEATS

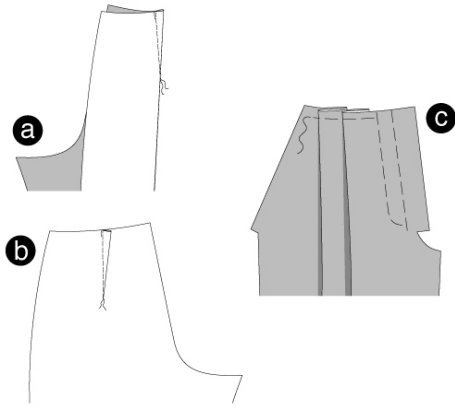

PANTS

DARTS

Stitch the darts on the back pant piece to a point. Knot threads. (a) Press darts towards the center back (b).

PANT PLEATS

Position the pleats on the right fabric side of the front pant pieces according to the arrows. Pin along the top edge. Stitch pleats. ©

Step 6 — YOKE | POCKETS | INSEAM | PANT LEGS

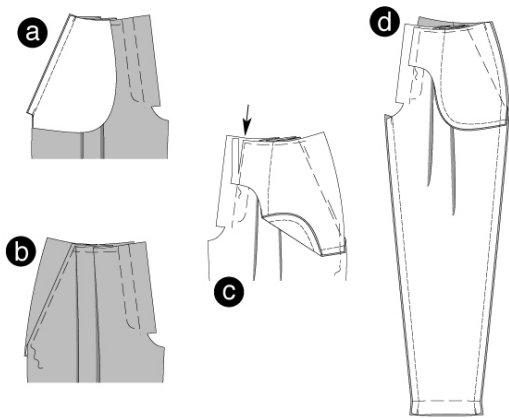

HIP YOKE POCKETS

Position the pocket pouches on the right front piece, right sides facing. Position the pocket opening edges together (seam number 1) and stitch. Trim allowances. Fold the pocket pouches to the inside. Pin. Press edges. (a)

Position the front pant pieces on the hip yoke piece; the pocket opening edge meets the marked line. Right fabric sides of pocket pouch and hip yoke meet. Pin pocket opening. (b)

Position the pocket pouch on the hip yoke piece. Pin; do not enclose the front pant piece. Stitch. Neaten allowances. Position the side, top and front edges of the hip yoke piece on the front pant piece. Pin. ©

Important: Cut the allowance at the center front of the right hip yoke piece.

SIDE SEAMS / INNER PANT LEG SEAMS

Position the front and back pant pieces together, right sides facing. Pin side seams (seam number 2) and inner leg seams (seam number 3). Stitch seams. Neaten allowances and press apart. (d)

Step 7 — CENTER FRONT SEAM | ZIPPER

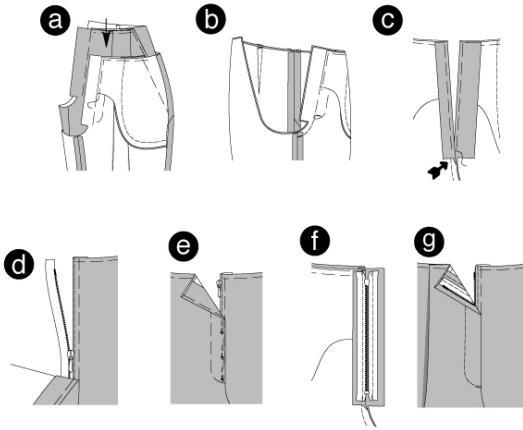

CENTER FRONT SEAM / ZIPPER

Turn one pant leg inside out. Push one pant leg inside the other, so right fabric sides meet. (a)

Stitch the center seam from the opening sign to the inner leg seams. Stitch the allowances; also, stitch along the front facing. (b)

On the right front pant piece, fold the facing at the center front inside and pin. On the left front pant piece, allow the facing to underlay $\frac{1}{4}$ " (0.7 cm) to cover the zipper later on. Fold the rest of the facing inside and pin. Press. ©

Position the underlay next to the zipper teeth along the zipper strip. Pin. Topstitch narrowly. Close zipper. (d) Position the opening edges together, centers meet (e).

Position the facing of the right opening edge on the zipper strip, not enclosing the front pant piece. Stitch the zipper strip on the facing. (f)

Stitch the right front pant piece along the stitch line, enclosing the facing. (g)

Step 8 — WAISTBAND | CENTER BACK SEAM | CLOSURE | HEMLINE

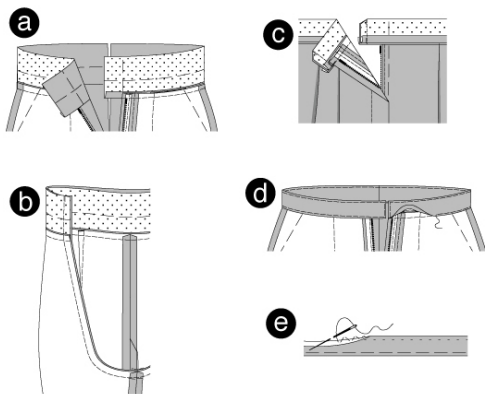

WAISTBAND

Position the waistband pieces on the top pant edge (seam number 4), right sides facing and center meeting. Stitch. Trim allowances and press inside the waistband. (a)

CENTER BACK SEAM

Push 1 pant leg inside the other, right sides facing. Pin the center seam along the waistband. Stitch center seam. Trim allowances and press from the top to the edge of the curve. Press the allowances of the long waistband edges inside. (b)

Fold the waistband along the fold line, right sides facing. Stitch the short front edges together; to the right at the center front and to the left at the underlay. Trim allowances and cut the corners at a slant. ©

Turn waistband right side out. Pin edges and press. Position the inner waistband on the seam line and pin. Topstitch waistband edges narrowly, enclosing the inner part. (d)

CLOSURE

Apply the hook under the right front waistband edge. Accordingly, apply the eye to the underlay.

HEMLINE

Neaten hemline, fold inside and press. Sew hemline by hand. (e)

BurdaStyle

Marilyn Trousers