

105 Trousers

Burda sizes 36, 38, 40, 42, 44

Side length 104 cm (41 ins)

Upper edge is 3 cm (1 1/4 ins) below waist

Hem circumference 35 cm (14 ins)

Materials

Cotton fabric, with lengthwise stripes,
width: 150 cm (59 ins)

length: 1.60 m (1 3/4 yds) for all sizes.

A piece of lining for the pockets, approx. 20 x 40
cm (8 x 16 ins).

Interfacing.

1 zip, 14 – 14 – 14 – 16 – 16 cm (5 – 5 – 5 – 7 – 7
ins) long.

1 flat inside button.

Recommended fabrics: Cotton trouser fabrics,
with or without elastane.

Preparations

Print the pattern out on letter or A4 sized paper.
It is **very** important to not scale the document.
Your pattern will print on multiple pages, which
you will then tile together. Arrange the sheets on
a large, hard and flat surface matching up the
numbers and letters (i.e. 6A to 6A). Cut or fold
one of the sides and match the edge to it's corre-
sponding side. Then, tape down in place so paper
is secure.

Trace the pattern pieces from the pattern sheet
following the lines and markings for style 105 and
your size. The stitching line at the zip slit is
marked for size 36. For sizes 38 – 44, mark the
stitching line the same distance from centre front
as for size 36, noting length of opening.

**burda style magazine patterns do not have seam
allowance included.**

Seam and hem allowance to be added:

Seams and edges 1.5 cm (5/8 in). Turn-up and
hem allowance are already included on the pat-
tern piece.

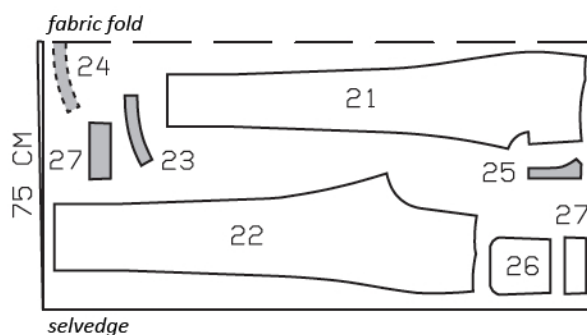
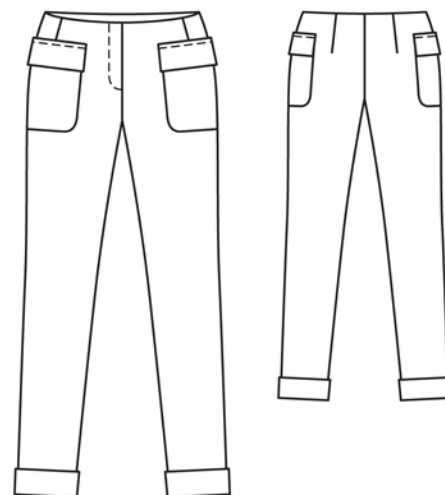
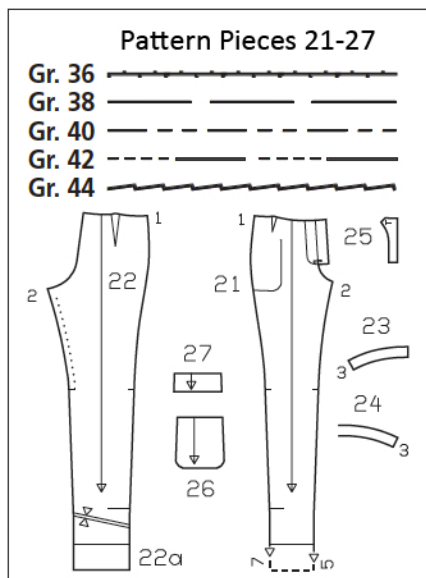

Cut from a double layer
of fabric, right side
facing in.

Cutting Out

Cotton fabric:

- 21 front trouser piece 2x
- 22 back trouser piece 2x
- 23 front facing 2x
- 24 back facing, on a fold 1x
- 25 left underlap piece 2x
- 26 pocket 2x
- 27 flap 4x

Lining: piece 26.

Interfacing: See shaded area on pattern layout.

Sewing

Stretch inside leg seam edges of back trouser pieces: Lay back trouser pieces together, right sides facing. Use a steam-iron to press inside leg seam edges above marking (or press under a damp cloth) to stretch them to match corresponding edges on front trousers.

Stitch darts and press toward centre.

Stitch side seams. Press seam allowances open.

Stitch pocket pieces of main fabric and lining together around all edges, leaving a section of seam open, for turning. Turn pocket right side out. Sew opening closed. Pin pockets to trouser pieces at placement line and edgestitch in place.

Stitch each interfaced flap piece to flap piece with no interfacing, right sides together, leaving attachment edge open. Turn right side out. Topstitch close to edges. Trim allowances on attachment edges to 5 mm (3/16 in). Stitch flaps to trouser pieces, 1 cm (3/8 in) above pockets. Press flaps down and stitch again 5 mm (3/16 in) from attachment seam.

Stitch inside leg seams. Press seam allowances open. Stitch centre front seam below slit mark and centre back seam as continuous seam. Press allowances of centre seam open from upper edge to beginning of crotch curve. Do not press seam allowances flat along curve.

Zip slit and upper trousers edge: Press self-facings on slit edges to inside, along centre front on the right and 5 mm (3/16 in) before centre front on the left. Stitch zip under left slit edge (underlap), stitching close to teeth of zip. Pin slit closed, matching centre fronts. Stitch loose zip tape to right facing, not catching trouser piece. Stitch both pieces for slit underlap together, right sides facing, leaving straight attachment edge open. Trim seam allowances. Turn underlap right side out and press. Neaten attachment edges together. Lay underlap under left slit edge and pin to facing. Stitch facing to underlap, close to zip attachment seam. Turn right slit facing to outside and pin to upper trousers edge. Pin (upper) facing to upper trousers edge, right sides together. On right slit edge, trim away al-

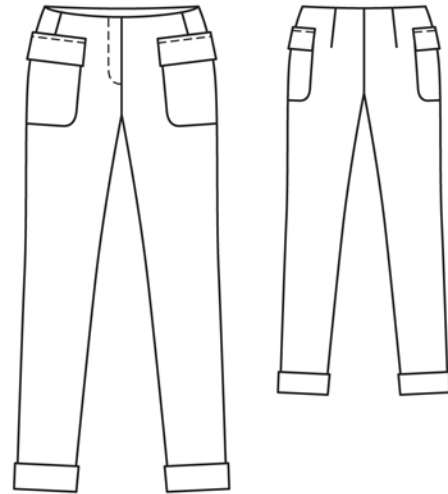

lowance of facing along centre front. Stitch along upper trousers edge. Turn facing up and stitch to seam allowances, close to seam. Turn facing end under at left slit edge. Turn upper facing and slit facing to inside. On left slit edge, sew facing to underlap attachment seam. Topstitch right slit edge vertically, from upper edge to 3 cm (1 1/4 ins) before end of slit, as marked, catching facing but not catching underlap. Lay slit closed again and topstitch to the end, catching underlap. Sew inside facing edge to seams and darts. Work buttonhole in underlap.

Turn-ups: Press trouser legs to inside on turn-up fold line and machine stitch or sew in place by hand. Turn lower trouser leg edges up to placement line and press. Sew turn-ups to the seams, with a few stitches.

Additional Information:

Burda patterns do not include seam and hem allowances. We recommend adding 1-2 cm (3/8 - 3/4 inch) for seams and 2-5 cm (3/4 - 2 inch/es) for hems. Refer to your specific pattern instructions for exact measurements.

The fabric requirements are based on the fabric used for the original designs. These amounts will change if you use fabric of a different width. The pattern of the fabric determines whether all the pieces must be cut in the same direction or whether some can be reversed to save fabric.

The cutting layout printed with the instructions shows the best way to place the pattern pieces on our original fabric. Fold the fabric double with the right side facing in. The fabric then has a fold edge and a selvedge edge. When cutting from a single fabric layer, the right side should face up.

Pattern pieces which are shown in the cutting layout with broken outlines should be pinned to the fabric with their printed side facing down.

Grey shaded areas in the cutting layout indicate which pieces are to be interfaced.

Transfer the pattern piece lines to the wrong side of your fabric with burda dressmaker's carbon paper. Hand-baste along lines (e.g. for pockets or centre front) to make them visible on the right side of the fabric.

Key Symbols:

Seam numbers

show where pattern pieces must be sewn together. Match pieces with the same numbers.

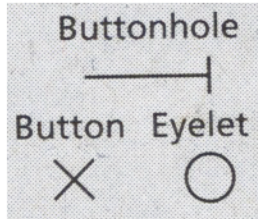

Seam marks

on long seams. Match the small symbols to one another.



Presser foot is the symbol for seam and top-stitching lines.



Scissors

indicate edges to be cut without seam allowances and also slash lines, e.g. pocket openings.



Pleat symbol

Fold pleat in direction of arrow.

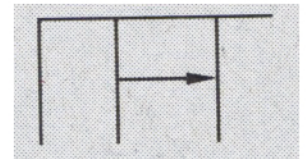

Placket/slit mark

Indicates beginning/ end of placket/slit.

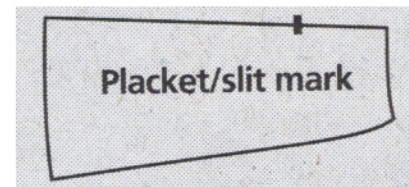

Gather
Ease
Stretch

