

140A Trousers

Burda sizes 44, 46, 48, 50, 52

Side length with waistband 110 cm

Upper waistband edge = waist

Hem circumference 53 cm (21 ins)

Materials

Crêpe satin,

width: 145 cm (57 ins)

length: 2.00 – 2.00 – 2.05 – 2.10 – 2.25 m

(2 1/4 – 2 1/4 – 2 1/4 – 2 3/8 – 2 5/8 yds).

Interfacing.

1 invisible zip, 22 cm (9 ins) long.

Recommended fabrics: Lightweight, softly draping trouser fabrics.

Preparations

Print the pattern out on letter or A4 sized paper. It is very important to not scale the document. Your pattern will print on multiple pages, which you will then tile together. Arrange the sheets on a large, hard and flat surface matching up the numbers and letters (i.e. 6A to 6A). Cut or fold one of the sides and match the edge to its corresponding side. Then, tape down in place so paper is secure.

Trace the pattern pieces from the pattern sheet following the lines and markings for style 140A and your size. Trace the pocket piece from piece 1 as a separate pattern piece – it is the same for all sizes.

burda style magazine patterns do not have seam allowance included.

Seam and hem allowance to be added:

Seams and edges 1.5 cm (5/8 in), hem 4 cm (1 5/8 ins).

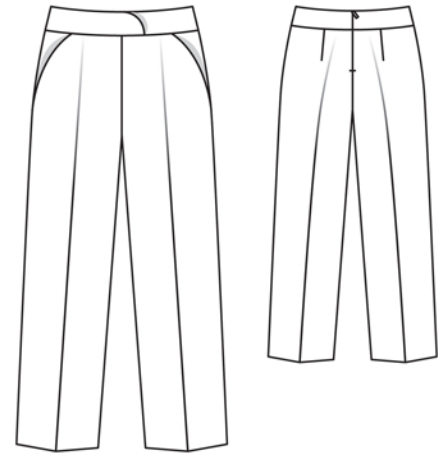
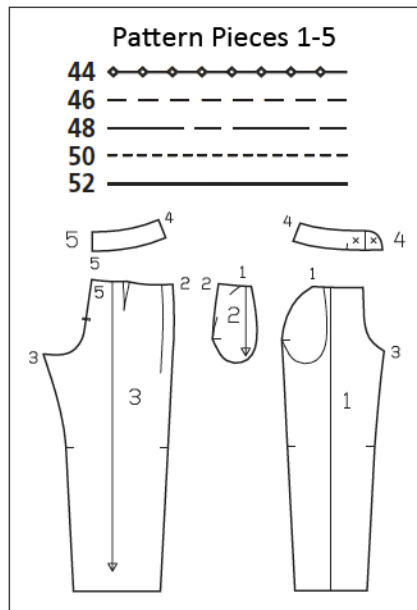

Sizes 44-50

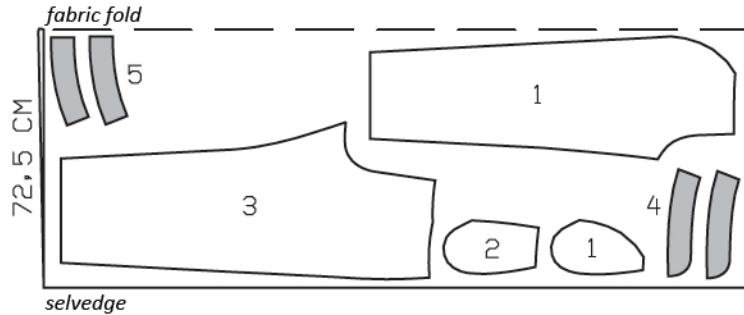

Size 52

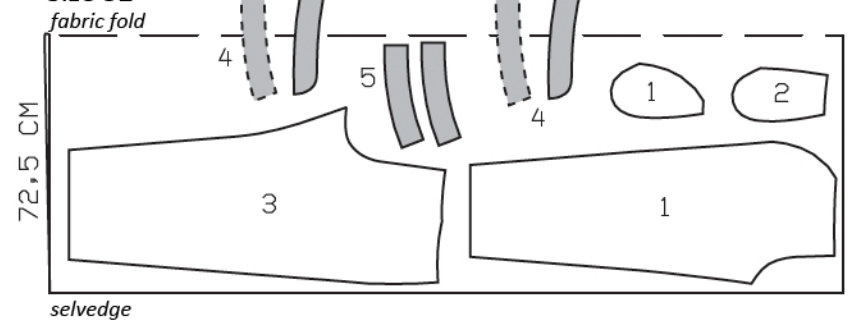

Cut from a double layer of fabric, right side facing in. The pieces shown laying over the fabric fold should be cut last from a single layer of fabric. Cut right and left pieces as opposites.

Cutting Out

Crêpe satin:

- 1 front trouser piece 2x
- pocket piece 2x
- 2 side hip yoke with integrated pocket piece 2x
- 3 back trouser piece 2x
- 4 front waistband 4x
- 5 back waistband 4x

Interfacing: See shaded area on pattern layout.

Sewing

Fold front trouser pieces lengthwise, with wrong side facing in, and press creases, ending approx. 10 cm (4 ins) above lower edge. Stitch back darts and press toward centre.

Hip yoke pockets: Stitch pocket pieces to pocket opening edges of front trouser pieces, right sides facing. Turn pocket pieces up and stitch to seam allowances, close to seam. Turn pocket pieces to inside. Pin pocket opening edges to side hip yokes, at placement lines. On inside, stitch pocket pieces together. Baste upper pocket piece edges in place.

Stitch side seams and inside leg seams. Press seam allowances open. Stitch centre front seam approx. 10 cm (4 ins) long, beginning at upper edge.

Stitch side seams on outer and inner waistband units. Lay pairs of waistband units together, right sides facing. Stitch across front waistband ends and along upper edges. Begin stitching on left front waistband exactly at seam line of attachment edge. Trim seam allowances. Turn waistband units right side out. Lay right front waistband on left front waistband, matching centre fronts. Stitch seam allowances of attachment edges together between markings, not catching inner left waistband piece. On inside right waistband piece, clip allowance at marking. Stitch waistband to upper trousers edge, right sides together with not catching inner waistband pieces. Press seam allowances onto waistband. Turn inside waistband up again at back waistband ends.

Sew invisible zip to back slit edges, beginning at upper waistband edge, see the "Helpful Hint" on next page. Turn in top ends of zip tapes and sew in place. Stitch remainder of centre front seam and centre back seam as continuous seam, up to zip.

On inside, baste waistband over attachment seam and sew to zip tapes. Work from right side of trousers to stitch along waistband attachment seam. Sew right front waistband end to left front waistband end with a few stitches by hand.

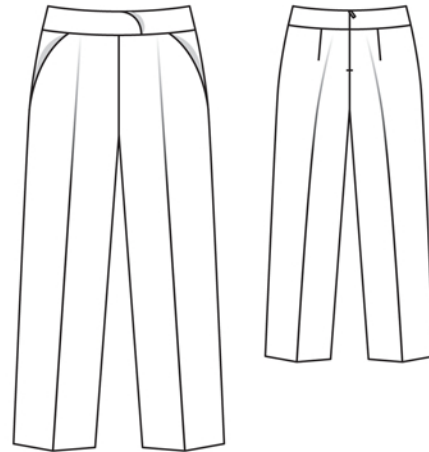

Press hem allowances to inside and sew in place by hand.

Press creases in trouser backs. Press remainder of front creases.



These special zippers come in various lengths. The zipper should be at least 2 cm (3/4 in) longer than the slit. It is sewn in place before the seam below the slit is stitched. A special presser foot is required to sew the zipper in place.

Sewing the zipper in place:

Open the zipper and push the coil back with your thumbnail to reveal the seam marking between the tape and the coil. Place the open zipper right side down on the right fabric side of one slit edge.

In order to stitch the zipper in place exactly along the marked seam line, you must first calculate the distance between the tape edge and the fabric edge as follows: width of seam allowance minus 1 cm (3/8 in) tape width = distance from edge of fabric. This will yield a value of 5 mm (3/16 in) if the width of the seam allowance is 1.5 cm (5/8 in).

Pin the top end of the zipper tape in place, the calculated distance from the edge of the fabric. The bottom end of the zipper will extend past the marked end of the slit. Place the presser foot on the zipper so that the coil is in the notch to the right of the needle (1). Stitch zipper in place, from the top to the marked end of the slit. Close zipper.

Place the other zipper tape face down on the opposite slit edge and pin in place at the top. Open zipper again. Place the presser foot on the top end of the zipper so that the coil is in the notch to the left of the needle (2). Sew the zipper in place, from the top to the end of the slit. Close zipper.

Now stitch the seam below the zipper, from bottom to top. Turn the loose lower end of the zipper out of the way, over the seam allowance. Stitch as close as possible to the last stitches of the zipper seams. Trim away excess zipper and bind the end with a scrap of fabric.

Additional Information:

Burda patterns do not include seam and hem allowances. We recommend adding 1-2 cm (3/8 - 3/4 inch) for seams and 2-5 cm (3/4 - 2 inch/es) for hems. Refer to your specific pattern instructions for exact measurements.

The fabric requirements are based on the fabric used for the original designs. These amounts will change if you use fabric of a different width. The pattern of the fabric determines whether all the pieces must be cut in the same direction or whether some can be reversed to save fabric.

The cutting layout printed with the instructions shows the best way to place the pattern pieces on our original fabric. Fold the fabric double with the right side facing in. The fabric then has a fold edge and a selvedge edge. When cutting from a single fabric layer, the right side should face up.

Pattern pieces which are shown in the cutting layout with broken outlines should be pinned to the fabric with their printed side facing down.

Grey shaded areas in the cutting layout indicate which pieces are to be interfaced.

Transfer the pattern piece lines to the wrong side of your fabric with burda dressmaker's carbon paper. Hand-baste along lines (e.g. for pockets or centre front) to make them visible on the right side of the fabric.

Key Symbols:

Seam numbers

show where pattern pieces must be sewn together. Match pieces with the same numbers.

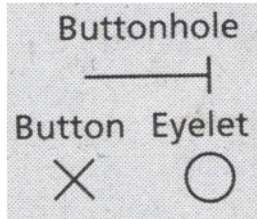

Seam marks

on long seams. Match the small symbols to one another.



Presser foot is the symbol for seam and top-stitching lines.



Scissors

indicate edges to be cut without seam allowances and also slash lines, e.g. pocket openings.



Pleat symbol

Fold pleat in direction of arrow.



Placket/slit mark

Indicates beginning/ end of placket/slit.



Gather
Ease
Stretch

