

108A Trousers

Burda sizes 36, 38, 40, 42, 44

Side length with waistband: 82 cm

Upper trousers edge is approx. 2 cm below waist, crotch lowered by 6.5 cm

Materials

Washed silk,

width: 135 cm (53 ins)

length: 1.40 – 1.50 – 1.60 – 1.60 – 1.60 m

(1 5/8 – 1 3/4 – 1 3/4 – 1 3/4 – 1 3/4 yds).

Interfacing.

1 zip, 15 cm (6 ins) long.

1 button and 1 flat inside button.

Recommended fabrics: Lightweight, softly draping trouser fabrics.

Preparations

Print the pattern out on letter or A4 sized paper. It is **very important** to not scale the document. Your pattern will print on multiple pages, which you will then tile together. Arrange the sheets on a large, hard and flat surface matching up the numbers and letters (i.e. 6A to 6A). Cut or fold one of the sides and match the edge to its corresponding side. Then, tape down in place so paper is secure.

Trace the pattern pieces from the pattern sheet following the lines and markings for style 108A and your size. Trace the pocket piece from piece 21 as a separate pattern piece. The stitching line at the zip slit is marked for size 36. For sizes 38 – 44, mark the stitching line the same distance from centre front as for size 36.

burda style magazine patterns do not have seam allowance included.

Seam and hem allowance to be added:

Seams and edges 1.5 cm (5/8 in), hem 4 cm (1 5/8 ins). Flare hem allowance at side seam edges and taper allowance at inner leg seam edges.

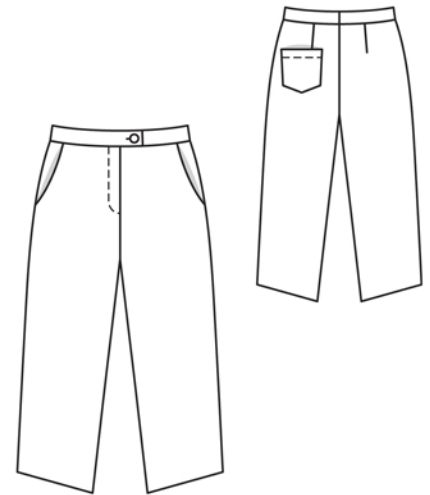
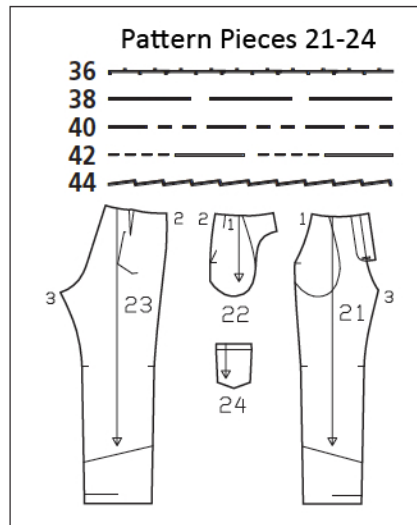

Sizes 36, 38

fabric fold

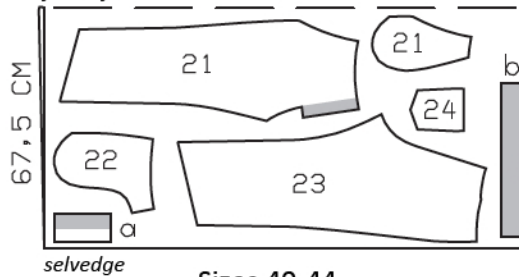

Cut from a double layer of fabric, right side facing in.

Sizes 40-44

fabric fold

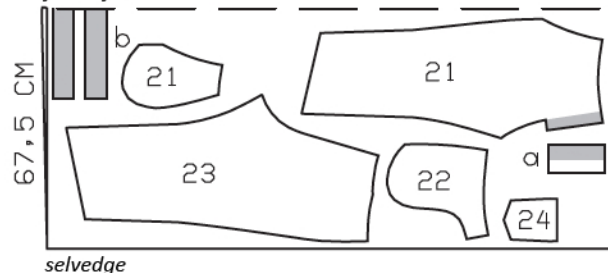

Cutting Out

- 21 front trouser piece 2x
- pocket piece 2x
- 22 side hip yoke with integrated pocket piece 2x
- 23 back trouser piece 2x
- 24 left back pocket 1x

Draft the following pieces NOT included in the pattern:

- a) left underlap piece, 16 cm (6 1/2 ins) long, 8 cm (3 1/4 ins), finished width 4 cm (1 5/8 ins),
- b) 2 waistband pieces each with 4.5 cm (1 7/8 ins) overlap and underlap, 43 – 45 – 47 – 49 – 51 cm (17 – 17 3/4 – 18 1/2 – 19 1/4 – 20 1/4 ins) long, 6 cm (2 1/2 ins) wide, finished width 3 cm (1 1/4 ins).

Interfacing: See shaded area on pattern layout.

Sewing

Stitch back darts and press toward centre.

Hip yoke pockets: Stitch pocket pieces to pocket opening edges of front trouser pieces, right sides together. Turn pocket pieces to inside. Topstitch close pocket opening edges. Pin pocket opening edges to side hip yokes, at placement lines. Stitch pocket pieces together. Baste pocket pieces to wrong side of front trouser pieces, first trimming away allowance of right pocket piece along centre front.

Left back pocket: Turn self-facing on upper pocket edge to inside, turn edge under, and stitch. Press allowances on side and lower edges to inside. Edgestitch pocket to left back trouser piece. Make small triangles of stitching at top corners of pocket.

Stitch side seams and inside leg seams. Press seam allowances open. Stitch centre front seam from slit mark to inside leg seam.

Zip slit: Press self-facings to inside. Stitch along centre front on the right and stitch 7 mm (1/4 in) before centre front on the left. Stitch zip under left slit edge (underlap), close to teeth of zip. Pin slit closed, matching centre fronts. Stitch loose zip tape to right facing, not catching trouser piece. Baste facing in place. Topstitch slit from upper edge to 3 cm (1 1/4 ins) before end of slit, as marked. Fold underlap piece lengthwise and stitch across bottom end. Turn right side out. Lay underlap under left slit edge and pin to facing. Stitch facing to underlap, close to zip attachment seam. Lay slit closed again and topstitch to the end, catching underlap. On left front trouser piece, press self-facing on slit edge to inside, 5 mm (3/16 in) before centre front.

Waistband and centre back seam: Stitch right and left waistband pieces to upper trouser edges, with waistband overlap extending at the right and stitching waistband underlap to opening underlap on the left. Press allowances of attachment seams onto waistband. Stitch centre back seam, stitching waistband ends together. Press seam allowances open from upper edge to beginning of crotch curve. Do not press seam allowances flat along curve. Press allowance on

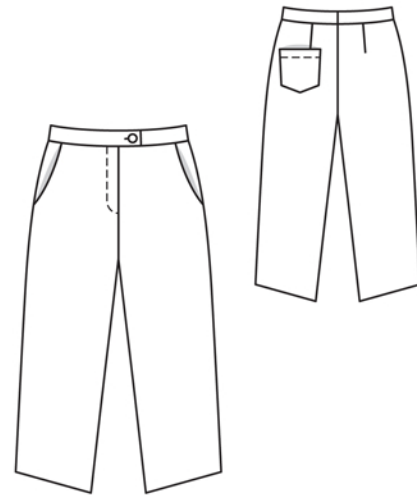

other long waistband edge to inside. Fold waistband lengthwise, with right side facing in, and stitch across left front waistband end. At overlap on the right, press seam allowances down again and stitch along lower overlap edge and right waistband end. Turn waistband right side out and press. Baste inside edge in place. Topstitch waistband close to all edges. Work a buttonhole in each end of waistband – on the left for inside button.

Press hem allowances to inside and sew in place by hand.

Additional Information:

Burda patterns do not include seam and hem allowances. We recommend adding 1-2 cm (3/8 - 3/4 inch) for seams and 2-5 cm (3/4 - 2 inch/es) for hems. Refer to your specific pattern instructions for exact measurements.

The fabric requirements are based on the fabric used for the original designs. These amounts will change if you use fabric of a different width. The pattern of the fabric determines whether all the pieces must be cut in the same direction or whether some can be reversed to save fabric.

The cutting layout printed with the instructions shows the best way to place the pattern pieces on our original fabric. Fold the fabric double with the right side facing in. The fabric then has a fold edge and a selvedge edge. When cutting from a single fabric layer, the right side should face up.

Pattern pieces which are shown in the cutting layout with broken outlines should be pinned to the fabric with their printed side facing down.

Grey shaded areas in the cutting layout indicate which pieces are to be interfaced.

Transfer the pattern piece lines to the wrong side of your fabric with burda dressmaker's carbon paper. Hand-baste along lines (e.g. for pockets or centre front) to make them visible on the right side of the fabric.

Key Symbols:

Seam numbers

show where pattern pieces must be sewn together. Match pieces with the same numbers.

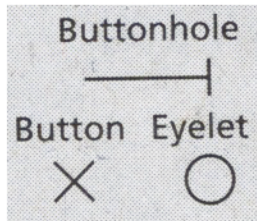
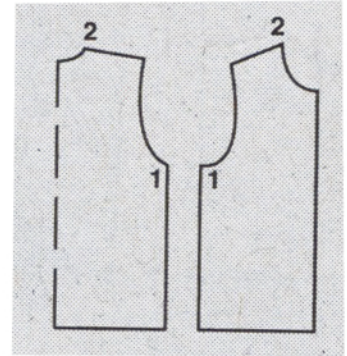

Seam marks

on long seams. Match the small symbols to one another.



Presser foot is the symbol for seam and top-stitching lines.

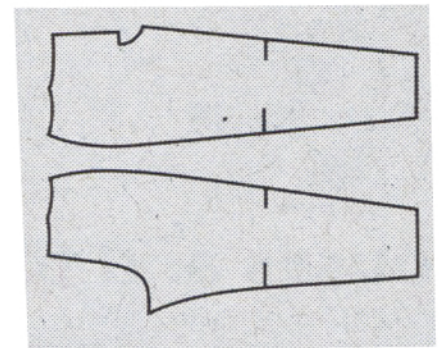

Scissors

indicate edges to be cut without seam allowances and also slash lines, e.g. pocket openings.



Pleat symbol

Fold pleat in direction of arrow.



Placket/slit mark

Indicates beginning/end of placket/slit.

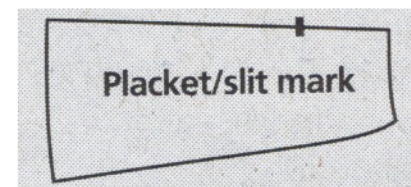

Gather
Ease
Stretch

