

105 Top

Burda sizes 36, 38, 40, 42, 44

Length from waist 32 cm (12 3/4 ins)

Materials

Jacquard taffeta,
width: 150 cm (59 in)
length: 1.00 m (1 1/8 yds) for all sizes.

Vilene Bias Tape/ stay tape.

1 invisible zip, 60 cm (24 ins) long.

Recommended fabrics: Lightweight fabrics with some body.

Preparations

Print the pattern out on letter or A4 sized paper. It is **very important** to not scale the document. Your pattern will print on multiple pages, which you will then tile together. Arrange the sheets on a large, hard and flat surface matching up the numbers and letters (i.e. 6A to 6A). Cut or fold one of the sides and match the edge to it's corresponding side. Then, tape down in place so paper is secure.

Trace the pattern pieces from the pattern sheet following the lines and markings for style 105 and your size. The stitching lines for the casing on pieces 21 and 22 are marked for size 36. For sizes 38 – 44, remark stitching lines the same distance from corresponding size lines.

burda style magazine patterns do not have seam allowance included.

Seam and hem allowance to be added:
Seams, edges and hem 1.5 cm (5/8 in).

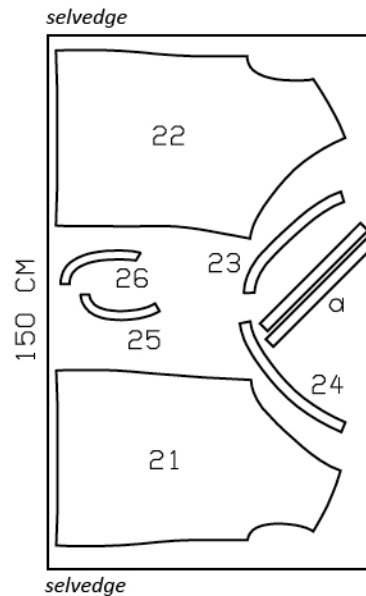
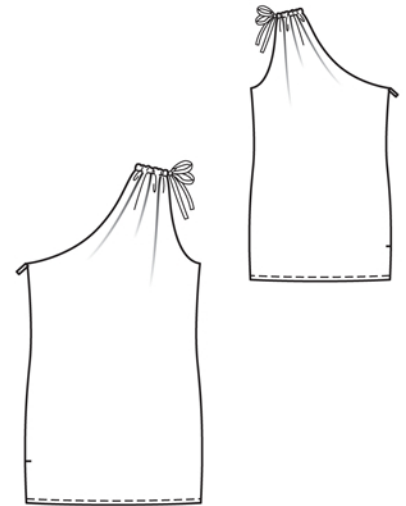
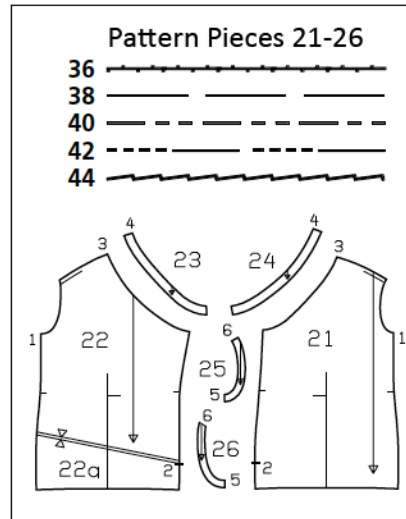

Cut from a single layer of fabric, right side facing up. Lay asymmetric pieces, printed side up, on the right side of the fabric.

Cutting Out

21 front	1x
22 back	1x
23 front neck facing	1x
24 back neck facing	1x
25 left front armhole facing	1x
26 left back armhole facing	1x

Draft the following piece NOT included in the pattern:

- a) 2 drawstring bands, cut on bias, 40 cm (16 ins) long, 3 cm (1 1/4 ins) wide (incl. allowances).

Vilene Bias Tape/ stay tape: Iron onto neck and armhole edges.

Sewing

Stitch left side seams on top and armhole facing. Stitch armhole facing right sides together with left armhole. Trim seam allowances. Lay facing over seam allowances into armhole and stitch to seam allowances, close to seam. Turn facing to inside, baste to shoulder edges, and sew to side seam.

Sew invisible zip to right side edges, see the "Helpful Hint" on next page. Stitch right side seam from lower edge to zip.

Front and back neck edge: Pin facings right sides together with neck edges of garment. At zip opening, turn facings back, about 5 mm (3/16 in) before edge of opening, and pin to upper edges. Turn allowances on slit edges of garment to outside and pin to neck edge, over facings. Stitch along neck edge. Turn allowances on slit edges to inside. Turn facings up and stitch to seam allowances, as far as possible, close to seam. Turn facings to inside and sew to zip tapes. Baste facings to shoulder edges.

Left shoulder seam with drawstring casings: Stitch left shoulder seam. Press seam open and stitch as marked, to form casings. Turn in one end of each drawstring band. Fold bands lengthwise, right side facing in. Stitch 5 mm (3/16 in) from fold edge. Turn bands right side out and press. Sew ends of bands closed. Pull drawstring bands into casings and stitch across ends of bands at neck edge.

Press hem allowance to inside, turn in, and stitch in place.

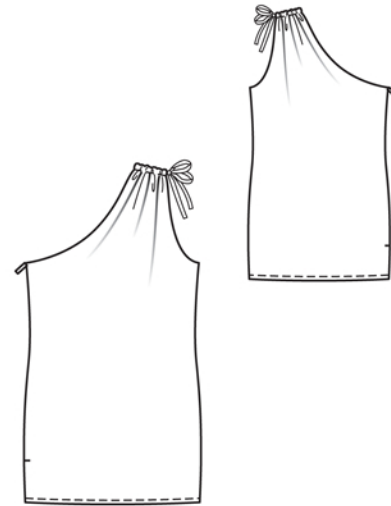



These special zippers come in various lengths. The zipper should be at least 2 cm (3/4 in) longer than the slit. It is sewn in place before the seam below the slit is stitched. A special presser foot is required to sew the zipper in place.

Sewing the zipper in place:

Open the zipper and push the coil back with your thumbnail to reveal the seam marking between the tape and the coil. Place the open zipper right side down on the right fabric side of one slit edge.

In order to stitch the zipper in place exactly along the marked seam line, you must first calculate the distance between the tape edge and the fabric edge as follows: width of seam allowance minus 1 cm (3/8 in) tape width = distance from edge of fabric. This will yield a value of 5 mm (3/16 in) if the width of the seam allowance is 1.5 cm (5/8 in).

Pin the top end of the zipper tape in place, the calculated distance from the edge of the fabric. The bottom end of the zipper will extend past the marked end of the slit. Place the presser foot on the zipper so that the coil is in the notch to the right of the needle (1). Stitch zipper in place, from the top to the marked end of the slit. Close zipper.

Place the other zipper tape face down on the opposite slit edge and pin in place at the top. Open zipper again. Place the presser foot on the top end of the zipper so that the coil is in the notch to the left of the needle (2). Sew the zipper in place, from the top to the end of the slit. Close zipper.

Now stitch the seam below the zipper, from bottom to top. Turn the loose lower end of the zipper out of the way, over the seam allowance. Stitch as close as possible to the last stitches of the zipper seams. Trim away excess zipper and bind the end with a scrap of fabric.

Additional Information:

Burda patterns do not include seam and hem allowances. We recommend adding 1-2 cm (3/8 - 3/4 inch) for seams and 2-5 cm (3/4 - 2 inch/es) for hems. Refer to your specific pattern instructions for exact measurements.

The fabric requirements are based on the fabric used for the original designs. These amounts will change if you use fabric of a different width. The pattern of the fabric determines whether all the pieces must be cut in the same direction or whether some can be reversed to save fabric.

The cutting layout printed with the instructions shows the best way to place the pattern pieces on our original fabric. Fold the fabric double with the right side facing in. The fabric then has a fold edge and a selvedge edge. When cutting from a single fabric layer, the right side should face up.

Pattern pieces which are shown in the cutting layout with broken outlines should be pinned to the fabric with their printed side facing down.

Grey shaded areas in the cutting layout indicate which pieces are to be interfaced.

Transfer the pattern piece lines to the wrong side of your fabric with burda dressmaker's carbon paper. Hand-baste along lines (e.g. for pockets or centre front) to make them visible on the right side of the fabric.

Key Symbols:

Seam numbers

show where pattern pieces must be sewn together. Match pieces with the same numbers.

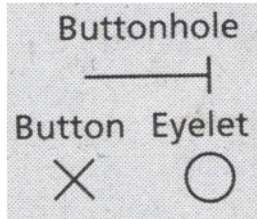

Seam marks

on long seams. Match the small symbols to one another.



Presser foot is the symbol for seam and top-stitching lines.



Scissors

indicate edges to be cut without seam allowances and also slash lines, e.g. pocket openings.



Pleat symbol

Fold pleat in direction of arrow.



Placket/slit mark

Indicates beginning/end of placket/slit.



Gather
Ease
Stretch

