

127A Jacket

Burda sizes 36, 38, 40, 42, 44

Back length: 62 cm (24 1/2 ins),

Materials

Shot taffeta,

width: 150 cm (59 ins)

length: sizes 36, 38, 40: 1.65 m (1 7/8 yds),
 sizes 42, 44: 1.70 m (1 7/8 yds).

Duchesse,

width: 150 cm (59 ins)

length: 0.75 m (7/8 yd) for all sizes.

Lining,

width: 140 cm (55 ins)

length: sizes 36, 38, 40: 1.30 m (1 1/2 yds),
 sizes 42, 44: 1.35 m (1 5/8 yds).

Interfacing, 90 cm (36 ins) wide: 1.90 m (2 1/8 yds) .

1 large button and 8 smaller buttons (sleeves).

Shoulder pads.

Recommended fabrics: Jacket fabrics with some body, with and without elastane.

Preparations

Print the pattern out on letter or A4 sized paper. It is **very important** to not scale or fit any of the pages, you must print the document in **actual size**. Your pattern will print on multiple pages, which you will then tile together. Arrange the sheets on a large, hard and flat surface matching up the numbers and letters (i.e. 6A to 6A). Cut or fold one of the sides and match the edge to it's corresponding side. Then, tape down in place so paper is secure. Trace the pattern pieces from the pattern sheet following the lines and markings for the correct size and the correct style (127A). This pattern also includes pattern pieces, lines and markings for style 127B that should be ignored. The piping attachment lines on piece 23 are marked for all sizes. The piping attachment lines on piece 21 are marked for size 36. For the other sizes, mark the piping attachment lines after stitching the front section seams (see piped pockets with flaps). The button markings on piece 24 are for size 36. For sizes 38 – 44, re-mark the buttons according to the size lines.

The button markings on piece 24 are for size 36. For sizes 38 – 44, re-mark the buttons according to the size lines.

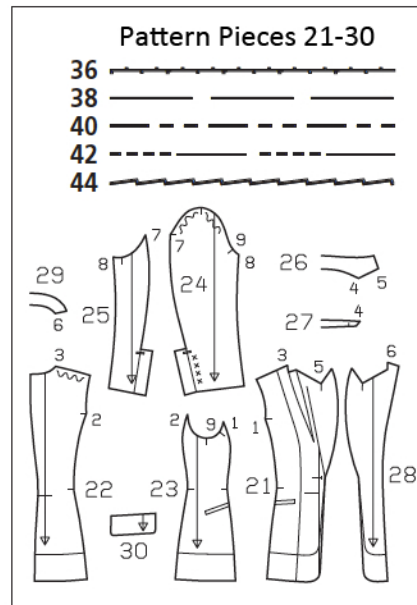

Shot Taffeta, 150cm wide *fabric fold*

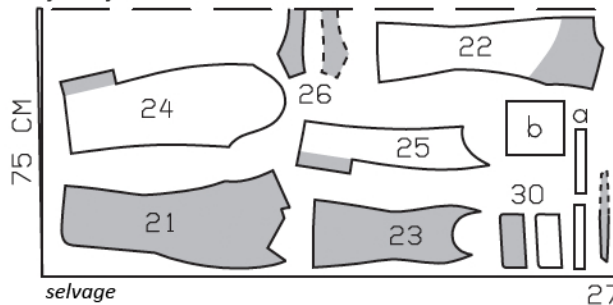

Duchesse, 150cm wide *fabric fold*

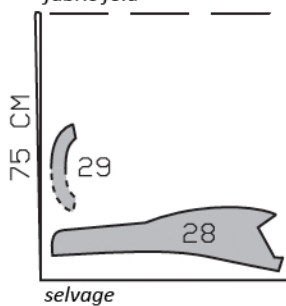

Lining, 140cm wide *fabric fold*

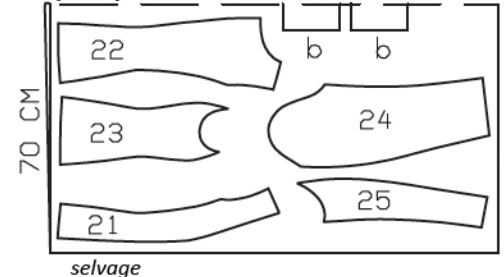

burda style magazine patterns do not have seam allowance included.

Seam and hem allowance to be added:

On sleeve pieces, no allowances on long edges of vent facing and underlap. 4 cm (1 5/8 ins) for hem and sleeve hems and 1.5 cm (5/8 in) at all other seams and edges. Cut out the fabric pieces on these lines. Lining: 3 cm (1 1/4 ins) for ease pleat at centre back and 1.5 cm (5/8 in) at all other seams and edges.

Cutting Out

Shot taffeta:

- 21 front 2x
- 22 back 2x
- 23 side piece 2x
- 24 upper sleeve 2x
- 25 under sleeve 2x
- 26 collar, on a fold 2x
- 27 collar stand, on a fold 2x
- 30 flap 4x

Draft the following pieces NOT included in the pattern:

- a) 4 piping strips, each 18 cm (7 1/8 ins) long, 4 cm (1 5/8 ins) wide (incl. allowances),
- b) 2 pocket pieces, each 18 cm (7 1/8 ins) wide, 19 cm (7 1/2 ins) high (incl. allowances).

Duchesse:

- 28 front facing 2x
- 29 back facing, on a fold 1x

Interfacing

See shaded area on the pattern layout. Also iron interfacing to hem allowances of back and sleeve pieces.

Lining:

Prepare pattern pieces: Cut lining pieces minus facing. To do this, trim paper pattern piece 21 on the marked LINING line. Lay paper pattern piece 29 on piece 22 and mark inside facing edge on back piece = lining line. Trim pattern piece along lining line. On sleeve pieces, trim away vent facing and underlap.

Cutting out the lining:

pieces 21, 22, 23, 24 and 25, and also pocket piece (b), each twice.



Sewing

Centre back seam:

Lay back pieces together, right sides facing. Pin centre back seam. Stitch. Press seam allowances open.

Front section seams:

Lay side pieces on front pieces, right sides facing. Pin section seams, matching seam marks and seam lines. Stitch (image 1). Press seams open.

Piped pockets with flaps:

For sizes 38 to 44, lengthen piping attachment lines from side pieces onto front pieces (vanishing chalk). Mark front ends for a finished length of 15 cm (6 ins).

For all sizes, use vanishing chalk to mark placement lines 6 mm (1/4 in) from piping attachment lines (= finished piping width).

Fold piping strips in half lengthwise, wrong side facing in. Press. Pin each piping strip in place, with fold edge meeting lower placement line – open edges of strip point up. Transfer ends of pocket to piping. Stitch each piping strip in place, 6 mm (1/4 in) from fold edge. Secure start and end of seam by backstitching (image 2).

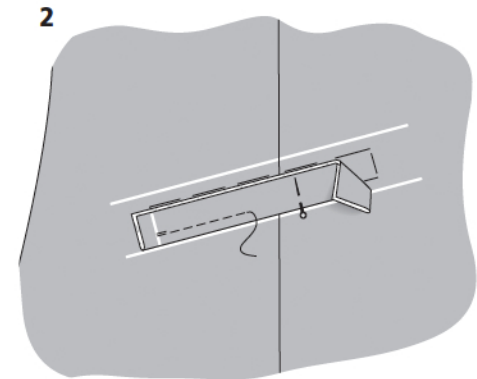
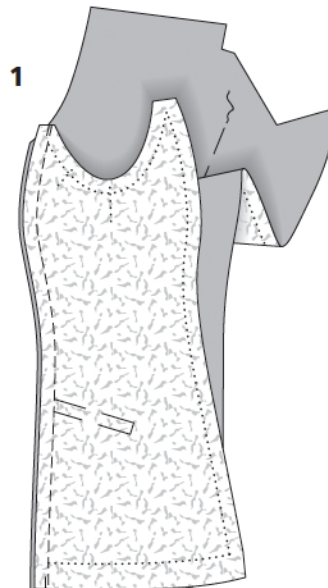

Sewing Continued...

Fold seam allowances of piping down and pin in place. Pin each of the two other piping strips to upper placement line – open edges point down. Mark ends of pockets and stitch piping in place, 6 mm (1/4 in) from fold edge (image 3). Slash between lines of stitching, beginning and ending 1 cm (3/8 in) before pocket ends and clipping diagonally toward each last stitch, to form small fabric triangles. Do not cut into piping (image 4). Turn piping toward pocket opening and turn piping ends to inside. Press seam allowances of piping attachment seams up/ down. Sew piping together by hand, with herringbone stitch (image 5). Fold small triangles at piping ends to inside and stitch to piping, from seam end to seam end (image 6). Pin each pocket lining piece to attachment seam of lower piping – lining pieces point up (image 7). Stitch seam allowances of piping to lining pieces, close to attachment seams (image 8). Press lining pieces down. Stitch each interfaced flap piece to flap piece with no interfacing, right sides together, leaving attachment edge open. Trim seam allowances. Turn flaps right side out. Press flaps. Mark placement line 6 cm (2 3/8 in) from lower edge of each flap (vanishing chalk). Remove herringbone stitches on piping. Slip flap between pipings, up to placement line, and pin flapt to upper piping attachment seam (image 9). Work from inside to pin pocket piece of main fabric to seam allowances of flap and upper piping. Stitch in place as described for pocket lining pieces. Pin pocket and lining pieces together, trim even, and stitch together.

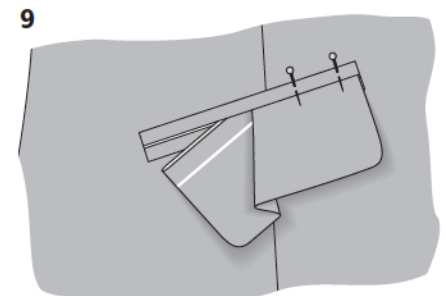
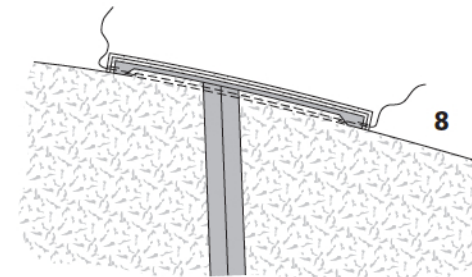
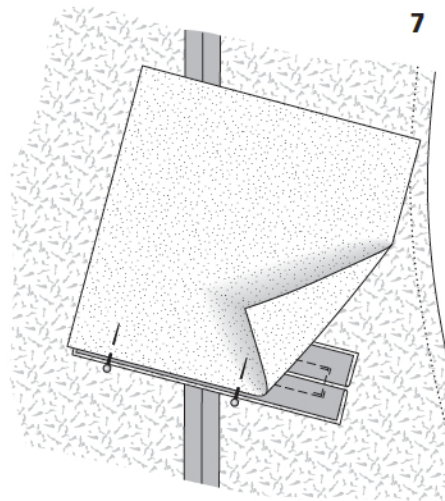
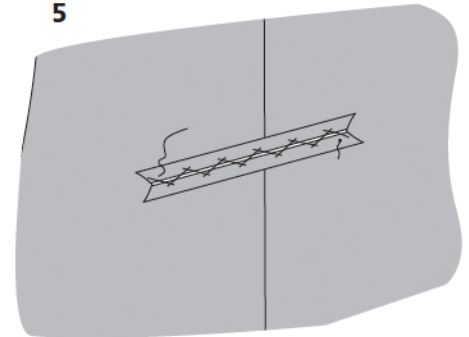
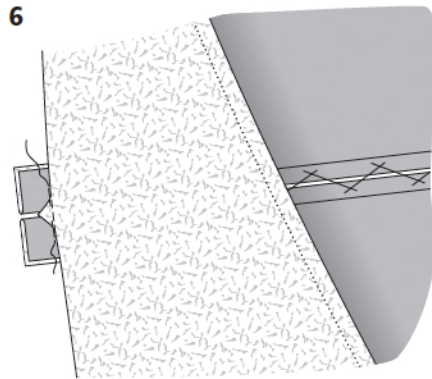
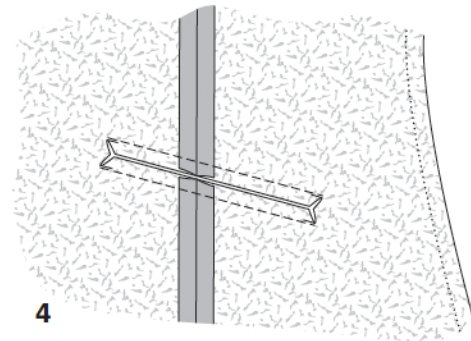
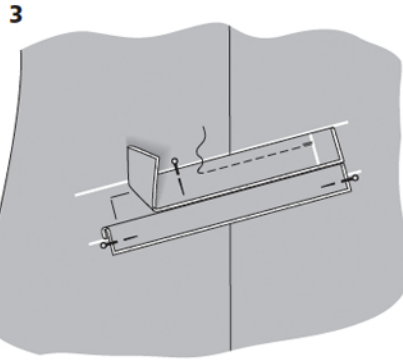

Sewing Continued...

On each front, cut between lines of lapel dart, approx. 10 cm (4 ins) long (image 10).

Lay fronts on back, right sides facing. Pin shoulder seams, easing back. Stitch shoulder seams. Press seam allowances open.

Sew collar:

Pin collar stand pieces to collar pieces, right sides facing (seam number 4). Stitch (image 11).

Trim seam allowances and press seams open.

Topstitch close to both sides of each seam.

Mark one collar piece with a chalk cross =

under collar. Lay collar pieces together, right sides facing. Pin collar stand attachment seams together. Roll the upper collar to add the required fullness. Pin long outer collar edges together, up to approx. 5 cm (2 ins) before the corners – seam lines do not meet (image 12).

Then roll collar corners and pin remaining collar edges together (image 13). Work from under collar side to stitch outer collar edges together, beginning and ending exactly at marked attachment seam. Trim allowances, trimming diagonally across corners diagonally (image 14). Turn collar right side out. Press edges.

Facing, front edges:

Stitch shoulder edges of back facing to shoulder edges of front facings, right sides together.

Press seams open. Lay facing on jacket fronts, right sides together, and pin along hem edges and front edges, up to lapel fold line, matching seam lines. Pin upper edges together at seam mark (seam number 5). Roll each jacket front on lapel fold line. Pin lapel edges together, up to approx. 5 cm (2 ins) before corners. Then pin lapel corners together as described for collar. Work from the jacket front side to stitch, beginning at lower edge, approx. 5 cm (2 ins) before inside facing edge and ending on lapel, exactly at seam mark (seam number 5). Leave facing lying on the jacket, right sides together, for the time being. Clip seam allowances into each lapel corner, close to last stitch (image 15).

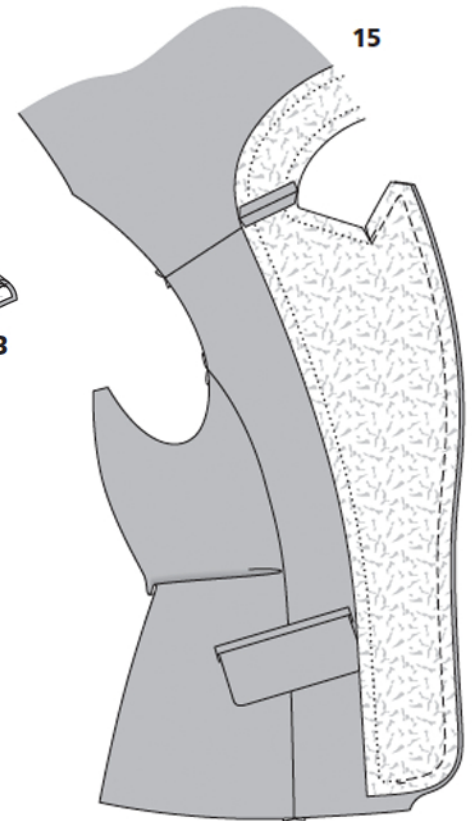
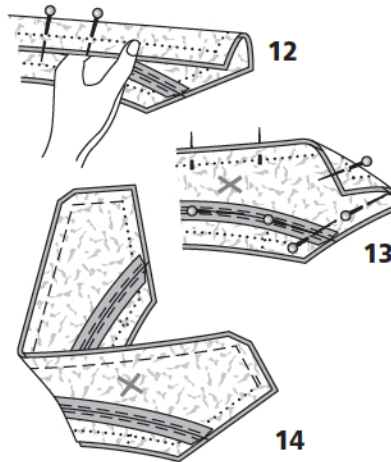
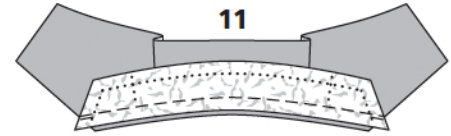
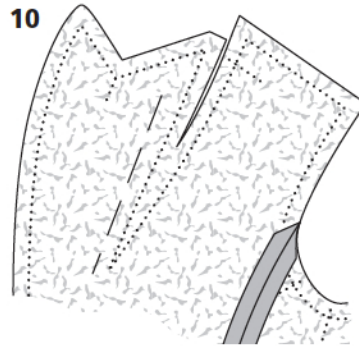

Sewing Continued...

Attach collar:

Slide collar between jacket and facing, with under collar lying on jacket. Pin under collar with collar stand to neck edge of jacket, from each seam mark to dart line, and pin top collar with collar stand to facing, up to corner. Stitch (image 16). Trim allowances of under collar attachment seams to 7 mm (1/4 in) wide and press open. Pin long edge of under collar stand to neck edge of jacket, beginning at centre back, then pin dart lines together. Stitch. Clip seam allowance of facing into corner, close to last stitch. Pin collar stand of top collar to facing, from corner to corner. Stitch (image 17). Trim seam allowances – including those on front edges and on hem edge, up to approx. 3 cm (1 1/4 ins) before seam end. Clip allowances along curves. Trim corners diagonally. Press allowances of collar attachment seams open. Turn facing to inside. Press edges – working from facing side to press from lower edge to lapel fold line, then working from outer side to press lapels. Pin collar attachment seams together exactly. Turn back facing up and stitch seam allowances together, close to collar attachment seam. Lay facing down again.

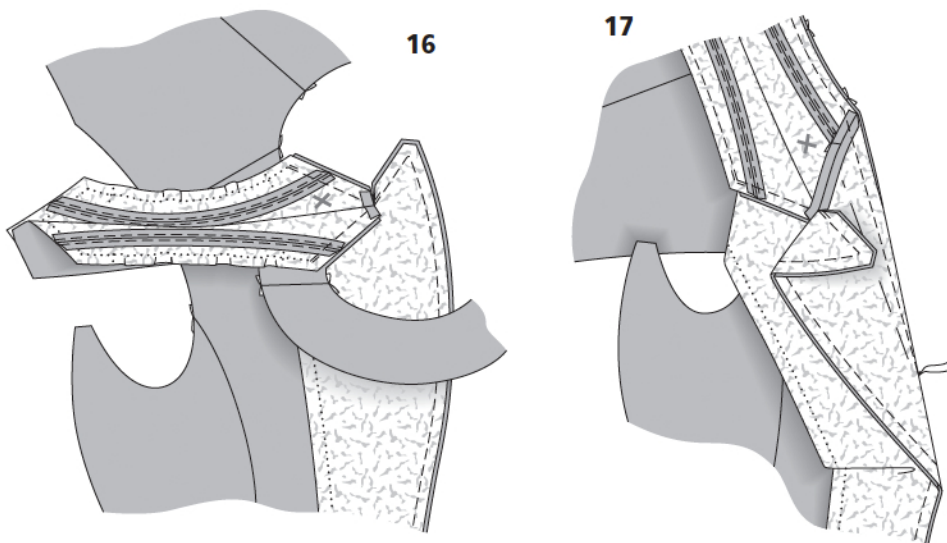

Sleeve vents:

At vent edge of each upper sleeve, turn hem allowance up, for the mitred corner. Mark hem allowance edge on vent facing with tailor's chalk (image 18). Lay hem allowance down again. Fold vent facing to inside and mark edge on hem allowance. Turn vent facing to inside again. Connect both markings and hem corner with a straight line (image 19). Fold sleeve at corner so that hem allowance lies on vent facing. Pin and stitch together along the chalk line, beginning 1 cm (3/8 in) before hem/ facing edge (image 20). Trim away corner 5 mm (3/16 in) from stitching line and trim diagonally at bottom corner (image 21).

Back section seams:

Lay side pieces on back, right sides facing. Pin back section seams. Stitch. Press seam allowances open.

Hem:

Press hem allowance to inside and stitch loosely by hand, leaving facing ends loose for the time being.

Sleeve seams:

Lay each under sleeve piece on upper sleeve piece, right sides facing. Pin back sleeve seams, from upper edge to slit mark (seam number 7). Stitch. Clip allowance of lower sleeve at end of underlap, close to line of stitching. Press seam allowances open.

To ease each sleeve cap, machine baste (longest stitch setting) between the dots, close to each side of seam line. Do not yet pull bobbin threads. Fold each sleeve lengthwise, right side facing in. Pin front sleeve seam (seam number 8). Stitch. Press seam allowances open.

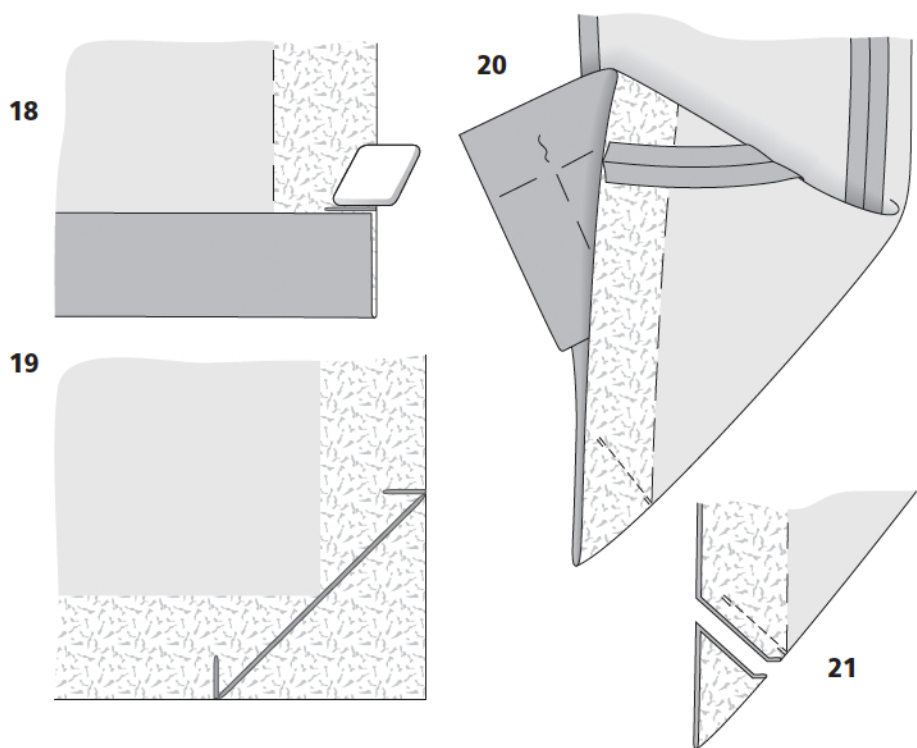

Sewing Continued...

Press allowances of mitring seam open. On vent underlap (under sleeve), turn hem allowance to right fabric side of sleeve and pin in place. Stitch hem allowance to underlap edge, 1 cm (3/8 in) from edge, ending 1 cm (3/8 in) below hem allowance edge (image 22). At end of seam, turn hem allowance down and pin in place. Clip vent underlap close to last stitch. At lower corner, trim allowance diagonally (image 23). Lay vent facing of upper sleeve on vent underlap (under sleeve), right sides facing. Pin edges together and stitch together from upper edge to clip (vent underlap), stitching 1 cm (3/8 in) from edge (image 24). Turn the hem allowances and the vent facing of upper sleeve to wrong side of sleeve. Press hem and vent edges (image 25). Sew hem allowance in place, loosely by hand. Sew buttons in place, as marked by x's, thereby catching the underlap.

Setting in sleeves:

First each pin sleeve to underarm curve, right sides facing, matching seam marks on under sleeve and side piece and matching seam mark 9 on upper sleeve and side piece (image 26). Then pin seam mark on sleeve cap to shoulder seam. Ease fabric of sleeve cap along bobbin threads of machine basting until sleeve matches armhole edge. Pin sleeve cap to armhole edge, distribute fullness evenly. Work from sleeve side to baste and stitch sleeve to armhole edge (image 27). Lay seam allowances in areas of sleeve caps toward sleeves. Sew shoulder pads in place.

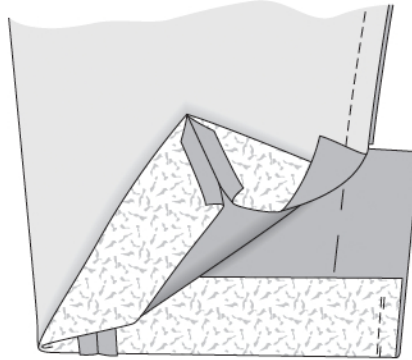
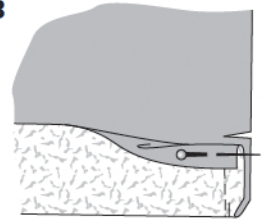
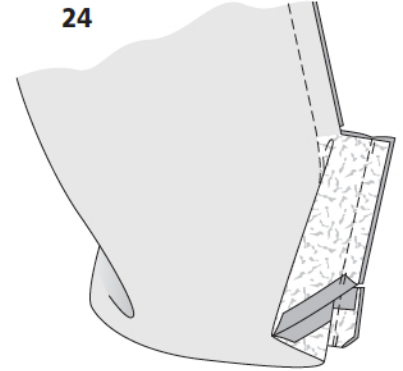
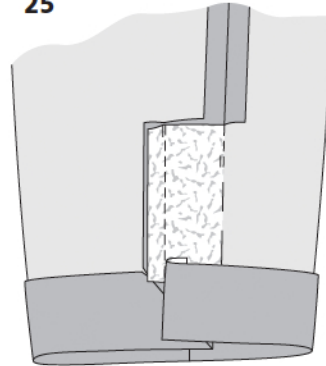
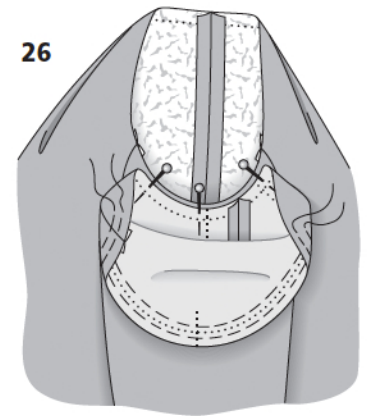
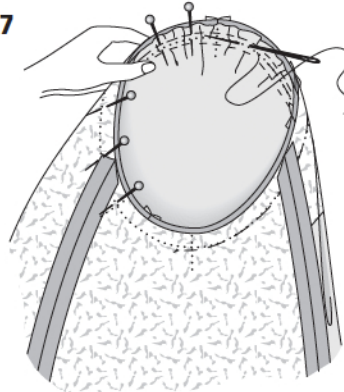
22**23****24****25****26****27**

Sewing Continued...

Sew lining:

For the ease pleat, stitch allowances of centre back seam together, 1 cm (3/8 in) from fabric edges, and baste in between. Stitch centre back seam from upper and lower edges, each approx. 5 cm (2 ins) long. Press pleat to one side. Stitch section seams, shoulder seams and sleeve seams, ending stitching of back sleeve seams at vents. Set in sleeves.

Sew lining to jacket:

Pin lining to inside facing edge, right sides together, turning allowance on lower facing edge flat down again to do so. Stitch (image 28). Lay lining inside jacket, with wrong sides facing and pulling linings into sleeves. Turn allowance on lower facing edge to inside again and turn lining edge under, along lower jacket edge. Press fold edge lightly. Push lower lining edge up in a shallow curve, toward upper edge of hem allowance and pin (image 29). Sew lining and lower facing edge to hem allowance.

Turn edges of sleeve linings under and sew to sleeve hem allowances.

Buttonhole, button:

Work buttonhole in right front edge as marked. Sew button to left front, to match buttonhole.

