

126A Skirt

Sizes 36, 38, 40, 42, 44

Skirt length 78 cm (30 3/4 ins)

Materials

Mini-herringbone with lamé effect,
width: 135 cm (53 ins)
length: 1.85 m (2 1/8 yds) for all sizes.

Interfacing.

Organza ribbon,
width: 1.5 cm (5/8 in)
length: 2.00 m (2 1/4 yds).

1 invisible zip, 22 cm (9 ins) long.

1 button.

Recommended fabrics: Lightweight skirt fabrics with some body. Soft tulle for the overskirt.

Preparations

Print the pattern out on letter or A4 sized paper. It is **very important** to not scale or fit any of the pages, you must print the document in **actual size**. Your pattern will print on multiple pages, which you will then tile together. Arrange the sheets on a large, hard and flat surface matching up the numbers and letters (i.e. 6A to 6A). Cut or fold one of the sides and match the edge to it's corresponding side. Then, tape down in place so paper is secure.

Trace the pattern pieces from the pattern sheet following the lines and markings for the correct size and the correct style (126). This pattern also includes pattern pieces, lines and markings for style 127 that should be ignored.

Trace pocket piece as a separate pattern piece – it is the same for all sizes.

burda style magazine patterns do not have seam allowance included.

Seam and hem allowance to be added:

Seams and edges 1.5 cm (5/8 in). Hem 3 cm (1 1/4 ins).

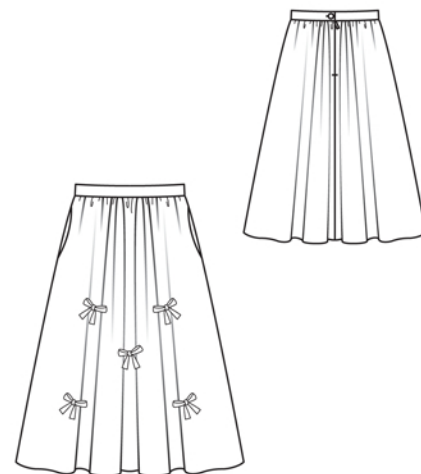
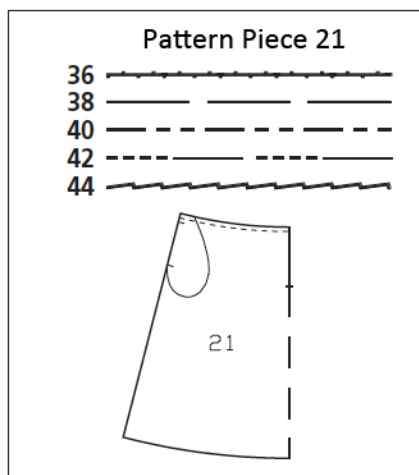

Cut from a double layer of fabric, right side facing in.

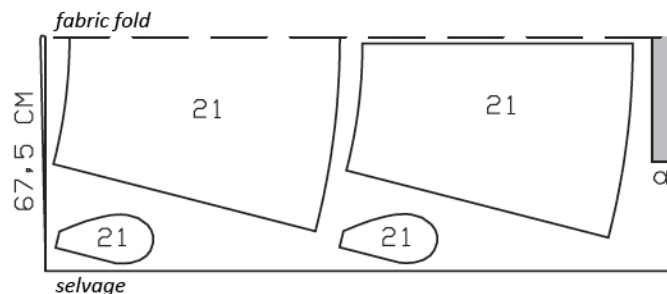

Cutting Out

Herringbone:

21 front skirt panel, on a fold 1x
pocket piece 4x
21 back skirt panel 2x

Draft the following piece NOT included in the pattern:

a) waistband with 3 cm (1 1/4 in) underlap, 72 – 76 – 80 – 84 – 88 cm (28 1/2 – 30 – 31 1/2 – 33 – 34 3/4 ins) long, 5 cm (2 ins) wide, finished width 2.5 cm (1 in).

Interfacing: Iron to waistband.

Sewing

Sew invisible zip to back skirt edges, see the “Helpful Hint” on next page. Stitch centre back seam from lower edge to zip. Press seam allowances open.

Stitch side seams, not stitching across pocket openings. Press seam allowances open.

Gather upper skirt edge to 69 – 73 – 77 – 81 – 85 cm (27 1/4 – 28 3/4 – 30 1/2 – 32 – 33 1/2 ins). Distribute the gathering so that skirt is gathered less at sides and more at the centre.

Inseam pockets: Work from inside to pin pocket pieces to seam allowances of pocket opening edges, right sides facing. Stitch in place directly along marked seam lines. Above pocket opening edges, stitch pocket pieces close to seam. Press pocket pieces forward and stitch together. Baste upper pocket edges in place.

Stitch waistband to upper skirt edge, leaving underlap extending at right back slit edge. Press seam allowances of attachment seam and of other long edge onto waistband. Fold waistband lengthwise, right side facing in. Stitch across ends. Turn right side out. Sew inside waistband edge along attachment seam by hand and sew underlap edges together. Work buttonhole in left waistband end.

Press hem to inside and sew in place by hand.

Cut 5 pieces of organza ribbon, each 40 cm (16 ins) long. Tie pieces in bows. Sew bows to skirt front, as illustrated.

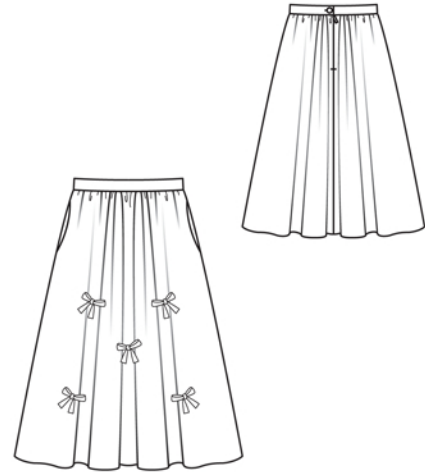



These special zippers come in various lengths. The zipper should be at least 2 cm (3/4 in) longer than the slit. It is sewn in place before the seam below the slit is stitched. A special presser foot is required to sew the zipper in place.

Sewing the zipper in place:

Open the zipper and push the coil back with your thumbnail to reveal the seam marking between the tape and the coil. Place the open zipper right side down on the right fabric side of one slit edge.

In order to stitch the zipper in place exactly along the marked seam line, you must first calculate the distance between the tape edge and the fabric edge as follows: width of seam allowance minus 1 cm (3/8 in) tape width = distance from edge of fabric. This will yield a value of 5 mm (3/16 in) if the width of the seam allowance is 1.5 cm (5/8 in).

Pin the top end of the zipper tape in place, the calculated distance from the edge of the fabric. The bottom end of the zipper will extend past the marked end of the slit. Place the presser foot on the zipper so that the coil is in the notch to the right of the needle (1). Stitch zipper in place, from the top to the marked end of the slit. Close zipper.

Place the other zipper tape face down on the opposite slit edge and pin in place at the top. Open zipper again. Place the presser foot on the top end of the zipper so that the coil is in the notch to the left of the needle (2). Sew the zipper in place, from the top to the end of the slit. Close zipper.

Now stitch the seam below the zipper, from bottom to top. Turn the loose lower end of the zipper out of the way, over the seam allowance. Stitch as close as possible to the last stitches of the zipper seams. Trim away excess zipper and bind the end with a scrap of fabric.